



IBU

IBU HANDBOOK

IBU HANDBOOK

on behalf of the IBU
edited by
Michael Geistfingler
assisted by Peter Bayer,
Franz Berger
and Max Cobb

Salzburg, Austria 2006 (4th edition)

INTERNATIONAL BIATHLON UNION
PEREGRINSTRASSE 14
A-5020 SALZBURG
AUSTRIA
Telephone: +43-662-85 50 50
Telefax: +43-662-85 50 508
E-Mail: biathlon@ibu.at
Homepage: <http://www.biathlonworld.com>



IBU

CONSTITUTION OF THE INTERNATIONAL BIATHLON UNION (IBU)

CONSTITUTION OF THE INTERNATIONAL BIATHLON UNION (IBU)

The editor would like to thank

Dmitriy Aleksashin,
Dr. Tjaša Andree-Prosenec,
Norbert Baier,
Anders Besseberg,
Mark Goodson,
Samuel Gray,
Ray Kokkonen,
Dr. Hans Kveli,
Dr. Klaus Leistner,
Vadim Melikhov,
Iannis Pandelidis,
Dr. Werner Scheuer and
Janez Vodičar

for their assistance and cooperation.

Note: In the Constitution and all Rules, all gender terms refer to male and/or female as appropriate. When used in a general context, the words he, him and his shall be taken to mean also she, her and hers respectively.

The IBU was founded on 2 July 1993 in Heathrow by London/GBR.

The Constitution was adopted on the same day.
Amendments were decided by the 1994, 1996, 1998, 2000, 2004 and 2006 Congresses. The current version of the Constitution was adopted by the 2006 Congress in Khanty-Mansiysk/RUS.

The Constitution was made subject to the Austrian legal order on the occasion of the founding of the seat of the IBU by the Congress at the 1999 Constituent General Assembly in Minsk/BLR.

LIST OF CONTENTS

ARTICLE 1	Name, Objectives, Headquarters, Language and Business Year	2
ARTICLE 2	Membership	3
ARTICLE 3	Termination of Membership	6
ARTICLE 4	Associated Organs	6
ARTICLE 5	Composition, Tasks and Responsibilities of the Associated Organs	6
ARTICLE 6	Conduct of Congress Sessions	8
ARTICLE 7	Conduct of Meetings of the Executive Board	12
ARTICLE 8	Duties of Executive Board Members	13
ARTICLE 9	Committees	14
ARTICLE 10	IBU Court of Arbitration and Appeals from IBU to the CAS	15
ARTICLE 11	Liability	16
ARTICLE 12	Conflict of Interest	17
ARTICLE 13	Auditing	17
ARTICLE 14	Rules	17
ARTICLE 15	Sanctions and Disciplinary Measures	18
ARTICLE 16	Use of the Funds and Assets in Case of a Dissolution of the IBU	18
ARTICLE 17	Broadcasting Rights for Radio, TV/Internet	18
ARTICLE 18	Entry into Force	18

ARTICLE 1 NAME, OBJECTIVES, HEADQUARTERS, LANGUAGE AND BUSINESS YEAR

- 1.1** The International Biathlon Union (IBU) is the association of the nations of the world participating in Biathlon and other organizations interested in the sport of Biathlon and sports similar to it such as Roller Biathlon, Cross Biathlon and Mountain Bike Biathlon. By way of friendly and dedicated cooperation of all the organizations, athletes and sports officials practicing the sport of Biathlon, the IBU shall contribute to the creation of a peaceful world. In accordance with the principles of the United Nations, no discrimination of any country or person on the grounds of race, religion, gender or political affiliation is allowed within the IBU.
- 1.2** Biathlon is a sport that combines cross-country skiing and rifle marksmanship and other forms of movement and shooting. Related sport forms are roller skiing and shooting (= Roller Biathlon), cross-country running and shooting (= Cross Biathlon), mountain biking and shooting and snowshoe trekking and shooting (= Snowshoe Biathlon). The IBU Event and Competition Rules provide further detailed information about the different sport forms associated with Biathlon.
- 1.3** The IBU shall promote the sport of Biathlon by supporting and developing it in the fields of competitive sports and popular recreational sports with special emphasis on the development of youth.
- The IBU shall promote teaching and training as well as sports refereeing in the sport of Biathlon. The IBU shall represent the International Biathlon sport in international sports organizations and in relations with the media, business, industry and sponsors.
- 1.3.1** The IBU shall have all rights pertaining to World Championships, Youth/Junior World Championships, Biathlon World Cup events, as well as Continental Championships, Continental Cups and Grand Prix. Any other international Biathlon event or competition with the intended participation of Athletes of IBU Member Federations will need prior authorization by the IBU and the respective Member Federation.
- 1.3.2** Before entering or prolonging a long-term contract concerning the use of the IBU rights, the Executive Board will consult the NFs most

important and/or most affected for the further development of the sport of Biathlon.

- 1.3.3** An IBU A Site License will be required to host World Championships and World Cups. An IBU B Site License will be required to host Y/J World Championships, Continental Championships and the Open European Cup.
- 1.4** The IBU does not aim at making any profit. The IBU will act as a non-profit-making organization and shall be managed on a honorary basis. No person may benefit from expenditures that are foreign to the Union's purpose or from disproportionately high remuneration.
- 1.5** The IBU shall serve exclusively and directly the non-profit purposes of its Member Federations. Any financial means of the Union may be used for statutory purposes, only.
- 1.6** English, German and Russian are official languages at the Congress. All other IBU Bodies are to decide their own working language. For the IBU Constitution, IBU Rules as well as for the documents and decisions of the IBU Bodies, the English version shall be the authoritative one.
- 1.7** The IBU is to work on the basis of this Constitution adopted by the Congress and shall endeavor to work in close cooperation with the IOC. This Constitution may not be contradictory to the Charter and the present regulations of the International Olympic Committee.
- 1.8** The business year of the IBU begins on 1 April and ends on 31 March.
- 1.9** The Headquarters of the International Biathlon Union is Salzburg/AUT.

ARTICLE 2 MEMBERSHIP

The IBU is composed of Provisional, Full, Extraordinary and Honorary Members. The provisional, full and extraordinary membership extends indirectly to all federations/organizations affiliated to the Member Federations/Organizations, as well as to individuals who are members of these Member Federations/Organizations.

- 2.1** **Provisional Members**
National Federations which wish to become Full Members of the IBU must apply for membership in writing and declare that they accept the purpose and the objectives of the IBU and its Constitution and

are officially recognised in their country by the National Olympic Committee or, if no such Committee exists, by the National Sports Body. The application for membership must be accompanied by a corresponding document that confirms this recognition. The Executive Board having examined the fulfilment of the preconditions will grant to the applicant the status of Provisional Member. This status will last at least for two years and will entitle the respective National Federation to register Athletes for IBU competitions, to organise IBU events and to take part at the Congress without the right to vote, as well as to be eligible to have members in IBU Committees. A Provisional Member must pay an annual membership fee which amounts to half of the membership fee paid by Full Members.

2.2 Full Members

Upon recommendation by the Executive Board, the Congress will accept National Federations, which have proved to be active in the development of the sport of Biathlon, as Full Members after the expiry of their term of provisional membership. Full members will be termed Member Federations hereafter.

2.3 Extraordinary Members

International Organizations that are interested in the Biathlon sport or a sport similar to Biathlon may become Extraordinary Members by applying in writing, as long as they accept the purpose and the objectives of the IBU.

2.4 Honorary Members

Honorary membership shall be conferred by the Congress upon persons who have rendered the IBU exceptional services. These persons must be recommended by the Executive Board or by National Federations through the channel of the Executive Board. Details about honorary membership are contained in the Rules for Honors.

2.5 Nationality of Athletes

The sphere of responsibility of the Member Federations is restricted to the territory of the country they represent. The respective Member Federation may only enter athletes who are citizens of the respective country. An athlete who is a citizen of two or more countries at the same time may represent either one of them, as he may elect. However, after having represented one country in the Olympic

Games, in Continental or Regional Games or in World or Continental Championships under the authority of the IBU, he may not represent another country, unless he meets the conditions for athletes having changed their citizenship or acquired a new citizenship. An athlete who has represented one country in the Olympic Games, in Continental or Regional Games or in World or Continental Championships under the authority of the IBU, and who has changed his citizenship or assumed a new citizenship may not participate in IBU competitions representing his new country until at least two years have passed since the athlete last represented his former country. This period may be reduced or even annulled, with the agreement of the IBU Member Federations concerned, by the Executive Board of the IBU, which will take into account the circumstances of each case. Stateless persons may participate for a Member Federation assigned by the IBU Executive Board upon authorization by the IBU Executive Board and with that Member Federation's agreement. For Olympic Winter Games, Rule 46 of the Olympic Charter shall apply.

2.6 Rights of Full Members

Each Member Federation has the right:

- a. to participate at the Congress, to file motions with the Executive Board and with the Congress, and to exercise the right to vote;
- b. to be heard in all matters which concern the Member Federation and to lodge an appeal;
- c. to nominate representatives to officiate in the IBU;
- d. to enter its Athletes for IBU competitions and all other competitions authorised by the IBU in accordance with the entry regulations for these competitions;
- e. to organize international Biathlon competitions that have been approved by the IBU;
- f. to inspect all agreements signed by the IBU as well as all agreements that concern the interest of the Member Federation or contain any liability for it and to be heard in such matters if need be.

2.7 Duties of Full Members

The Member Federations are obligated:

- a. to agree to promote the aims of the IBU and to comply with the IBU Constitution as well as with the rules and decisions taken by the Congress and the Executive Board,

- b. to pay the annual fee or whatever other contributions are established by the Congress in time,
- c. to fulfil all the requirements in connection with the participation at IBU events,
- d. to assure, as far as possible, that in the respective country only events and competitions in Biathlon are organised that have been authorized in advance by the respective Member Federation at the national level and by the IBU at the international level.

ARTICLE 3 TERMINATION OF MEMBERSHIP

- 3.1** Any class of membership will be terminated by:
- a. leaving the Union
 - b. being excluded from the Union
 - c. after the dissolution of the International Biathlon Union.
- 3.2** The Congress will expel a member that continues to seriously violate the Constitution of the IBU, especially acting against the aims and principles of the IBU that are laid down in Article 1.

ARTICLE 4 ASSOCIATED ORGANS

- 4.1** The IBU has the following Organs:
- a. the Congress
 - b. the Executive Board
 - c. the Court of Arbitration.
- 4.2** The IBU aims to represent men and women in all associated Organs and IBU Committees.

ARTICLE 5 COMPOSITION, TASKS AND RESPONSIBILITIES OF THE ASSOCIATED ORGANS

- 5.1** The Congress is the highest associated Organ. It consists of the representatives of the Full Members, of the non-voting representatives of the Provisional and Extraordinary Members, of the non-voting Executive Board and of the non-voting Chairpersons of the IBU Committees and the Auditors.

The Congress shall:

- receive the reports made by the Executive Board,
- ratify the actions and decisions of the Executive Board,
- appoint the Election Committee,

- elect the Executive Board,
- elect two impartial and independent Auditors,
- elect the Technical Committee,
- approve the budget plans,
- determine the membership fees,
- deal with and decide on principle matters of the sport of Biathlon,
- decide on the Event and Competition Rules,
- decide on the Anti-Doping Rules,
- make decisions on other rules as far as they do not fall within the authority of the Executive Board,
- make decisions on amendments to the Constitution,
- confirm amendments to the IBU Constitution (according to article 5.2.3 below) and to all other IBU Rules, which have been made by the Executive Board within its authority to expedite proceedings,
- appoint event hosts for Men's and Women's World Championships,
- confirm the affiliation of Full and Extraordinary Members with immediate effect from the passing of the respective resolution,
- appoint honorary members,
- confirm the removal from an IBU function,
- discharge the Executive Board,
- dissolve the Union,
- appoint the host of the next Congress,
- remove and replace members of the Executive Board in case of unsatisfactory performance (a 2/3 majority is required for this).

5.2 THE EXECUTIVE BOARD

- 5.2.1** The Executive Board is to be composed as follows:
- one President;
 - one First Vice-President, Deputy of the President;
 - one Vice-President for Finances;
 - one Vice-President for Sport;
 - one Vice-President for Marketing;
 - one Vice-President for Information;
 - one Vice-President for Development;
 - one Vice-President for Medical Issues;
 - one Vice-President for Special Projects;
 - the Secretary General as a non-voting member.

- 5.2.2** Between the Congress meetings, the Executive Board is responsible for the IBU. The Executive Board shall act on the basis of and in

accordance with this Constitution as well as with the decisions made by the Congress.

- 5.2.3** The tasks of the members of the Executive Board are established in the Rules for the Executive Board. Contracts must be signed by the President and the Vice-President for Finances in order to become effective. The Executive Board shall manage the business of the International Biathlon Union. In urgent cases, the Executive Board shall be authorised to amend IBU law subject to the approval of the next following Congress. Amendments to the Constitution by the Executive Board shall only be allowed if they are required by the law or the authorities of Austria. The Executive Board is authorized to enlist the help of committees, coordinators and experts and may enact rules regarding their activities.
The Executive Board is in charge of awarding IBU licenses.

ARTICLE 6 CONDUCT OF CONGRESS SESSIONS

6.1 Summoning

- 6.1.1** The Executive Board has to convene an ordinary Congress every two years in even years between June and September. It may also convene extraordinary Congresses if this appears to be necessary in its judgement. It has to convene an extraordinary Congress if more than two (2) members of the Executive Board have resigned or if a well-founded motion has been made to this end by one-tenth (1/10) of the Member Federations or if such a decision is made by the simple majority of the Executive Board. An extraordinary Congress must be held within 6 weeks after the receipt of the motion.

- 6.1.2** The Executive Board will determine the place and the time of the extraordinary Congress.

- 6.1.3** The Congress will be prepared by the Secretary General.

- 6.2** **Invitations to attend the Congress** must be sent out to the members by the Secretary General of the IBU 120 days before the beginning of the Congress. The invitation must be accompanied by a registration form. Each Member Federation eligible to vote may take part in the Congress with a maximum number of three persons.

6.3 Notification of Participation

The National Federations have to notify the Headquarters of the International Biathlon Union regarding their participation at the Congress with the registration form, at least 90 days before the beginning of an ordinary Congress and 30 days before the beginning of an extraordinary Congress.

6.4 Motions

Motions can be made by Full Members and by the Executive Board. The Chairpersons of the Committees may only file motions through the channel of the Executive Board. Motions from Full Members must be signed by the respective President or Secretary General. Motions by Full Members must be submitted in writing not later than 90 days before an ordinary Congress to the Headquarters of the International Biathlon Union. The Headquarters will distribute all motions duly received together with the final agenda to the Member Federations, to the Extraordinary Members, to the Executive Board and to the Chairpersons of the Committees. Motions that arrive late or are brought forward during the course of the Congress can be discussed and ruled upon if more than 50% of the voting members taking part at the Congress are in favor of allowing these motions. Motions to change the Constitution or to change the purpose of the Union, as well as motions aiming at the dissolution or at a fusion of the Union can only be dealt with if they are included in the final agenda that was distributed to the members. Motions to an extraordinary Congress must be submitted not later than 35 days before Congress begins to the IBU Headquarters, which in turn will distribute all motions received in the same way as for a regular Congress.

6.5 Announcement of the Agenda

The Headquarters of the IBU must send the agenda to the members early enough so that there is a period of 30 days between the day when the agenda is being dispatched and the beginning of an ordinary Congress, and 14 days in the event of an extraordinary Congress.

6.6 Chair and General Public

The Congress will be chaired by the President, or in his absence by the First Vice-President. All invited members of the IBU will be eligible for participation at the Congress. It shall be held as a closed

session. The President can decide to open parts of the Congress to the public.

6.7 **Announcement of the Number of Votes**

At the beginning of the Congress, the Secretary-General will announce the number of those eligible to vote based on roll call of Member Federations who have fulfilled their membership fee obligations.

6.8 **Right to Vote**

Full members whose membership fees for the Congress period have been paid to the IBU account not later than on the day of the beginning of the Congress or who have paid their fee directly to the Vice-President for Finances not later than on this day have one vote. The members of the Executive Board and the Chairpersons of the Committees are not eligible to vote.

The representatives of the Full Members will exercise the right to vote for them. Deferring the right to vote to others (voting by proxy) is forbidden. Members of the Executive Board and Chairpersons of the Committees may not make use of a Full Member's right to vote during their term of office.

6.9 **Elections, Confirmations, Execution of Office**

Only those persons can be elected to the Executive Board, the Technical Committee or as an Auditor, that have been proposed in writing by a National Federation or by another voting member 90 days before the election. If the proposal is made by another voting member, the National Federation of which the proposed person is a member must agree to the proposal. Proposed candidates must confirm their agreement to their candidacy verbally, by telephone or in writing. The personal presence of the candidate is desirable, but not mandatory. The elections for all Bodies will be made for a period of four years. The persons elected will remain in office until the new elections. Retired officials will be required to be available for the assignment procedures and briefings relating to their replacement for a period of 20 days following the new elections. An elected member of the Executive Board and a member of the Technical Committee of the IBU can be recalled by his National Federation on compelling grounds following previous consultation with the Executive Board of the IBU, or by the Congress before his term of office has ended. If a member of an associated Organ is absent for three meetings

between regular IBU Congresses without justified reason, or retires or is recalled before the term has ended, or is permanently unable to execute his office, the Executive Board must request nominations from all National Federations and must fill the vacant office provisionally until the next Congress with one of the nominated candidates. At the next Congress, new nominations and/or elections must take place.

6.10 **Election Committee**

The Election Committee shall consist of a chairperson and two more members that will be elected by the Congress at the beginning of the Congress. The Election Committee shall have the task of conducting the elections.

6.11 **Quorum**

A duly called Congress shall be competent to pass a resolution regardless of the number of the votes present.

6.12 **Passing of Resolutions**

Resolutions will be passed with a simple majority. For elections of the Executive Board and for voting on the appointment of event hosts for World Championships, resolutions will be passed according to the IBU Rules for Elections. In the case of a tie, the motion is to be considered rejected. The procedures for cases of a tie at elections are laid out in the IBU Rules for Elections. For all elections and voting, only the votes for and against will count. A secret ballot will be held if a voting member requests to do so. Changes to the Constitution or individual deviations from the Constitution in cases of urgency or amendments to the purpose of the Union, as well as motions aiming at the dissolution or the fusion of the Union must be carried by a 2/3 majority of the voters taking part at the Congress.

6.13 **Minutes**

For each Congress, the recording secretary (Secretary General or another person appointed by the Executive Board to do this) has to prepare Minutes, which must include – besides the resolutions – confirmation that the Congress had been convened according to the provisions of the Constitution, the number of Members' votes accounted for, the number of votes present and the results by numbers of the elections and votes. The Minutes must be accompanied by a list of attendees. The Minutes must be signed by

the Chairperson of the Congress and by the recording secretary. The Minutes must be distributed to all members within four weeks after the Congress. The Minutes shall be considered approved if there is no written objection by a member within four weeks after the Minutes have been dispatched. The next following meeting of the Executive Board must deal with any objections arising from the Minutes.

ARTICLE 7 CONDUCT OF MEETINGS OF THE EXECUTIVE BOARD

- 7.1** **The meeting** will be convened by the President or by the First Vice-President acting on his behalf.
- 7.2** **The President or the First Vice-President** acting on his behalf must convene a meeting within two weeks, if this is requested by at least two members of the Executive Board.
- 7.3** **The President or the First Vice-President** acting on his behalf will determine the place and time of the meeting.
- 7.4** **The meeting will be chaired** by the President or by the First Vice-President. The meetings shall be closed to the public. The chairperson can permit additional persons to attend the meeting, however, they will only be in the capacity of an advisory function. Each representative of a Full Member of the IBU and each person holding an office in the IBU has the right to present his matters of concern at the next meeting of the Executive Board.
- 7.5** **Passing of Resolutions**
The Executive Board shall be competent to pass resolutions if at least 50% of its voting members are present. All resolutions can be passed by a simple majority. If there is a tie, the Chairperson's vote will be the deciding vote. There will be no voting by proxy. Resolutions may also be passed in writing, by telefax, by electronic mail or by telephone if no member of the Executive Board objects to this procedure.
- 7.6** **Minutes**
The Minutes of the meetings must be prepared and must contain the names of the persons present and all resolutions that were passed. They must be signed by the recording secretary and must be distributed to the members of the Executive Board within 2 weeks after the meeting. If no member of the Executive Board objects to the Minutes within 2 weeks after they have been dispatched, the

Minutes shall be considered as having been approved. If one or more members raise an objection, this must be dealt with at the next meeting of the Executive Board and the Minutes cannot be approved until then. For resolutions that have been passed by means of writing or by means of phone, a memorandum must be written immediately stating agreement to this procedure, the resolutions that were passed and the names of the persons involved. This memorandum must be distributed to the members of the Executive Board immediately. Following approval by the Executive Board, the Minutes of the meetings of the Executive Board must be distributed to the Chairpersons of the Committees and to the Member Federations.

ARTICLE 8 DUTIES OF EXECUTIVE BOARD MEMBERS

- 8.1** The President directs the IBU; he is responsible for the work done by the Executive Board. He shall represent the IBU in public, in relations with third parties and international organizations. Before the Executive Board and/or the Committees enter obligations/contracts or assume tasks, he must give his approval. He shall take the chair in the meetings of the Congress and of the Executive Board. He shall supervise the activities of the IBU and fulfilment of the delegated tasks. The President may enlist the help of experts to fulfil his tasks. He has the authority to have investigations made in the Committees that are subordinate to the Congress. It is his duty to submit a written report to the Congress 30 days before the beginning of the Congress. If the President cannot officiate, the First Vice-President will act on his behalf.
- 8.2** The First Vice-President is responsible to act as deputy for the President.
- 8.3** The Vice-President for Finances is responsible for the financial affairs of the IBU, for establishing and implementing the IBU budget plan; he shall act as the IBU financial representative in public, shall report the financial situation to the Executive Board and to the Congress, and shall sign all contracts of the IBU together with the President.
- 8.4** The Secretary General is proposed by the President and appointed by the Executive Board. He is a non-voting member of the Executive Board. He shall manage the day-to-day business of the IBU in

accordance with the resolutions passed by the Executive Board and the Congress. He shall be in charge of the IBU Headquarters.

ARTICLE 9 COMMITTEES

9.1 Within the International Biathlon Union, the Technical Committee is to be elected by the Congress.

9.2 Within the International Biathlon Union, the Executive Board can establish the following and other Committees:

- Medical Committee
- Development and Regional Committee
- Marketing Committee
- Information Committee.

The Executive Board shall have the right to appoint the members of the aforementioned Committees for four years. The Member Federations will be asked to propose their own candidates. The National Federations of all appointees must be notified.

9.3 At their first meeting, the Committees will propose their Rules and submit them to the Executive Board for approval. The Committee responsible can make changes to its Rules with the approval of the Executive Board. The chairpersons of the Committees shall present their reports to the Executive Board not later than 60 days before the beginning of the Congress.

9.3.1 Technical Committee
The Technical Committee shall consist of 10 members who shall be elected by the Congress. At its first meeting, the Technical Committee shall elect a chairperson from among its members. The Technical Committee may invite other persons to its meetings if this is necessary. The Technical Committee may establish sub-committees, in particular for International Referees. The tasks of the Technical Committee are laid out in the Rules for the Technical Committee.

9.3.2 Medical Committee
The Executive Board shall appoint the members of the Medical Committee. The IBU Vice-President for Medical Issues should be the chairperson. The Medical Committee is obligated to cooperate closely with the Medical Committee of the IOC. The tasks of the Medical Committee are laid out in the Rules for the Medical Committee.

9.3.3 Development and Regional Committee
The Executive Board shall appoint the members of the Development and Regional Committee. The IBU Vice-President for Development shall chair the meetings. The tasks of the Development and Regional Committee are laid out in the Rules for the Development and Regional Committee.

9.3.4 Marketing Committee
The Executive Board shall appoint the members of the Marketing Committee. The IBU Vice-President for Marketing shall chair the meetings. If need be, the Marketing Committee may enlist the help of experts at the meetings. The tasks of the Marketing Committee are laid out in the Rules for the Marketing Committee.

9.3.5 Information Committee
The Executive Board shall appoint the members of the Information Committee. The IBU Vice-President for Information shall chair the meetings. If need be, the Information Committee is entitled to invite experts to attend its meetings. The tasks of the Information Committee are laid out in the Rules for the Information Committee.

9.4 The Executive Board will establish a Legal Committee.

9.5 The Executive Board will establish an Athletes' Committee within the IBU. The Athletes' Committee is to comprise of two female and two male Athletes who shall be confirmed by the Executive Board upon proposal of an Athletes assembly. The Athletes are to decide on their proposal for a four year term on the occasion of the first World Championships after the Olympic Games. At its first meeting the Athletes' Committee shall elect a chairperson from its members. The tasks of the Athletes' Committee are laid out in the Rules for the Athletes' Committee.

ARTICLE 10 IBU COURT OF ARBITRATION AND APPEALS FROM IBU TO THE CAS

10.1 **The IBU Court of Arbitration**, as an independent institution, shall be made up of three arbitrators of whom at least the chairperson must have the qualification of a judge or comparable juridical qualification.

10.2 **The Court of Arbitration** is responsible for:

- arbitrating in controversies between the IBU and its members and between members of the IBU;

- b. ruling on the appeal of a member against his expulsion by the Congress;
- c. ruling on appeals against penalties or disciplinary measures imposed by the Executive Board or the Congress;
- d. ruling on disagreements arising from IBU contracts and agreements as well as from declarations within the IBU.

10.3 The appointment of the arbitrators and the court procedures are laid down in Article 11 and 15 of the IBU Disciplinary Rules.

10.4 These rules also apply to proceedings under Article 10.2. a. and d., whereby the applicant shall take the position of the appellant and the respondent the position of the IBU Executive Board or the Congress.

10.5 In the case of proceedings under article 10.2. b., the provisions referred to are to be applied in such a way that the Congress of the IBU takes the position of the IBU Executive Board.

10.6 There shall be appeal to the Court of Arbitration for Sport (CAS), Lausanne, against decisions of the IBU Court of Arbitration in doping matters. In addition to the parties involved in the arbitration case, any other Anti-Doping Organization under whose rules a sanction could have been appealed, the International Olympic Committee, where the decision may have an effect on the Olympic Games, and WADA shall have a right to appeal to the CAS against the decision of the IBU Court of Arbitration or against the decision of the IBU Executive Board if the decision of the IBU Executive Board has not been appealed internally. The procedures concerned are governed by the respective rules of the CAS.

10.7 The IBU Executive Board and the Athlete shall also have the right to appeal to the CAS against decisions of WADA concerning the granting and denying of a Therapeutic Use Exemption. The procedures are governed by the respective rules of the CAS.

ARTICLE 11 LIABILITY

The IBU shall be liable for members of the Executive Board, of the Committees, of the Court of Arbitration, of the Competition Juries, of the Juries of Appeal, for Technical Delegates and International Referees for all actions that the Persons concerned have performed

in good faith and in such a manner for the IBU that there is good reason to believe that they had acted for the benefit of the IBU and not against it.

ARTICLE 12 CONFLICT OF INTEREST

An elected member of a Body of the IBU cannot be engaged on the basis of an employment contract or as a functionary within the IBU Headquarters unless he resigns from his elected function. However, such a person has the right to receive appropriate compensation for loss of earnings, if his personal work on behalf of or to the benefit of the IBU justifies such compensation.

ARTICLE 13 AUDITING

Every year the Executive Board shall hire a certified auditor or a professional auditing company to conduct the audit. This company will audit the finances or account books of the International Biathlon Union, the management of the International Biathlon Union's finances, the correctness and completeness of the vouchers and their correspondence with the bookkeeping and the annual balance sheet. He will prepare his audit report in the language of the country and present it to the Executive Board. The Executive Board has to pass the audit reports and all Minutes of all meetings of IBU Bodies to the Auditors elected by the Congress. These Auditors will conduct their audit annually, however in even years not later than 90 days before the Congress, and will check that the decisions of the Congress have been carried out. They will prepare a report in English about the auditing and present this report to the IBU Headquarters 60 days before the Congress. The Executive Board is obligated to distribute the audit report to the Member Federations together with the agenda for the Congress.

ARTICLE 14 RULES

The Executive Board will formulate the following specific rules in cooperation with the respective IBU Committees:

- The Event and Competition Rules
- The Anti-Doping Rules
- The Disciplinary Rules
- The Rules for the Technical Committee

- The Rules for Honors
 - The Rules for Elections
 - The Rules for Flag and Hymn
- and submit them to the Congress for decision.

ARTICLE 15 SANCTIONS AND DISCIPLINARY MEASURES

15.1 Penalties and disciplinary measures may be imposed in accordance with the IBU Disciplinary Rules, which are part of the Constitution.

15.2 Additional provisions are laid out in the Disciplinary Rules.

ARTICLE 16 USE OF THE UNION'S FUNDS AND ASSETS IN THE CASE OF A DISSOLUTION OF THE IBU

In case of dissolution of the Union, the Congress has to decide on the use of the Union's assets and to appoint two liquidators (lawyers/certified accountants) for the implementation of the dissolution ruling. In the case of dissolution or abolition of the Union or in the event of termination of its present purpose, the property of the Union, as far as it exceeds the capital shares paid by the members and the common value of the contributions in kind of the members, may only be used for not-for-profit, charitable or church purposes in the sense of the BAO (Austrian Federal Tax Regulations).

ARTICLE 17 BROADCASTING RIGHTS FOR RADIO, TV/INTERNET

All rights and arrangements relating to TV (including Internet) coverage of IBU World Championships for Men and Women and IBU World Cup Events shall be retained and exercised by the IBU only. The Executive Board shall be free to enter special arrangements with Member Federations.

ARTICLE 18 ENTRY INTO FORCE

This Constitution became effective as of 2 July 1993. It was amended by the 1994, 1996, 1998, 2000, 2004 and 2006 Congresses. The last amended version came into force on 3 September 2006.



IBU DISCIPLINARY RULES

Adopted by the IBU Congress 1994
with amendments by the 1996,
1998, 2000, 2002, 2004 and 2006 Congresses.

LIST OF CONTENTS

ARTICLE 1 Legal Basis..... 2
ARTICLE 2 Scope 2
ARTICLE 3 Conduct Leading to Penalties and Disciplinary Measures 2
ARTICLE 4 Prerequisites for Penalties and Disciplinary Measures 2
ARTICLE 5 Rules for Certain Potential Multiple Anti-Doping Rule Violations 4
ARTICLE 6 Automatic Invalidation of Results..... 5
ARTICLE 7 Penalties 5
ARTICLE 8 Disciplinary Measures and Sanctions on Member Federations 11
ARTICLE 9 Organs and Competency 13
ARTICLE 10 Jury of Appeal 14
ARTICLE 11 IBU Court of Arbitration 15
ARTICLE 12 Procedure for the Competition Jury 15
ARTICLE 13 Procedure for the Executive Board 16
ARTICLE 14 Appeal Proceedings for the Jury of Appeal 17
ARTICLE 15 Appeal Proceedings for the IBU Court of Arbitration 17
ARTICLE 16 Exemption from Liability 19
ARTICLE 17 Entry into Force 19

ARTICLE 1 LEGAL BASIS

The IBU Disciplinary Rules are issued on the basis of Article 14 of the Constitution of the IBU.

ARTICLE 2 SCOPE

The IBU Disciplinary Rules are applicable to all members of the IBU and all participants in the activity of the IBU or any of its National Federations by virtue of the participant’s membership, accreditation or participation in the IBU or its National Federation activities or events.

ARTICLE 3 CONDUCT LEADING TO PENALTIES AND DISCIPLINARY MEASURES

3.1 Athletes will be subject to penalties.

3.2 Coaches, trainers, officials and staff of the IBU and its Member Federations, individual members of the IBU and members of competition committees as well as any other participant under article 2 above will be subject to disciplinary measures.

3.3 Penalties and disciplinary measures shall be imposed for:
 - violations of the principles of fair play and unsportsmanlike conduct, especially for offences against the IBU Event and Competition Rules and against the IBU Anti-Doping Rules;
 - violations of the Constitution and other Rules of the IBU – as well as for violations of decisions of the Organs of the IBU;
 - endangering or impairing the reputation or the interests of the IBU and for impairing the contractual relations of the IBU;
 - offences against the IBU, its Organs, its members, the organs of its members or persons belonging to its members.

ARTICLE 4 PREREQUISITES FOR PENALTIES AND DISCIPLINARY MEASURES

4.1 With the exception of doping matters, persons who culpably, i.e. wilfully or negligently commit an infringement of the rules will be subject to penalties or disciplinary measures. For doping matters, the concepts underlying the World Anti-Doping Code and the IBU Anti-Doping Rules article 1.2.2 will apply.

- 4.2** With the exception of doping matters, in the case of petty violations, the IBU may refrain from imposing a penalty or a disciplinary measure and may instead rebuke the offender or issue a warning.
- 4.3** With the exception of doping matters, the respective IBU Bodies may refrain from imposing a penalty or impose a milder penalty if the Person makes a sincere attempt to repair the damage that has been caused to the sporting community or the victim.
- 4.4** If a Person establishes in an individual case involving a violation of Article 1.2.2 (Presence of a Prohibited Substance or its Metabolites or Markers), 1.2.3 (Use of a Prohibited Substance or Prohibited Method), 1.2.4 (Failing to submit to Sample collection), or 1.2.9 (Administration of a Prohibited Substance or Prohibited Method) of the IBU Anti-Doping Rules that he bears no Fault or Negligence for the violation, the otherwise applicable ban period may be eliminated. When a Prohibited Substance or its Markers or Metabolites is detected in an Athlete's Specimen in violation of Article 1.2.2 of the IBU Anti-Doping Rules, the Person must also establish how the Prohibited Substance entered his system in order to have the ban period eliminated. In the event this article is applied and the ban period otherwise applicable is eliminated, the anti-doping rule violation shall not be considered a violation for the limited purpose of determining the ban period for multiple violations under article 5 below.
- 4.5** If a Person establishes in an individual case involving a violation of Article 1.2.2 (Presence of a Prohibited Substance or Prohibited Method), 1.2.3 (Use of a Prohibited Substance or Prohibited Method), 1.2.4 (Failing to submit to Sample collection), or 1.2.9 (Administration of a Prohibited Substance or Prohibited Method) of the IBU Anti-Doping Rules that he bears no significant Fault or Negligence, then the ban period may be reduced, but the reduced ban period may not be less than one-half of the minimum ban period otherwise applicable. If the otherwise applicable ban period is a lifetime, the reduced period under this Article may be no less than eight (8) years. When a Prohibited Substance or its Markers or Metabolites is detected in an Athlete's Specimen in violation of Article 1.2.2 of the IBU Anti-Doping Rules (Presence of Prohibited Substance), the Person must also establish how the Prohibited Substance entered his system in order to have the ban period reduced.

- 4.6** In an individual case where a Person has provided substantial assistance to the IBU or any other Anti-Doping Organization which results in their discovering or establishing an anti-doping rule violation by another Person involving Possession under article 1.2.7 b. (Possession by Athlete Support Personnel), 1.2.8 (Trafficking) or 1.2.9 (Administration to an Athlete) of the IBU Anti-Doping Rules, the ban period may be reduced. The reduced ban period may not, however, be less than one-half of the minimum ban period otherwise applicable. If the otherwise applicable ban period is a lifetime, the reduced period under this Article may be no less than eight (8) years.

ARTICLE 5 RULES FOR CERTAIN POTENTIAL MULTIPLE ANTI-DOPING RULE VIOLATIONS

- 5.1** A second rule violation may be considered for purposes of imposing sanctions only if the IBU can establish that the Athlete or Person under Article 3.2 above committed the second anti-doping rule violation after the Athlete or Person under Article 3.2 above received notice, or after the IBU made a reasonable attempt to give notice, of the first rule violation; if the IBU cannot establish this, the violations shall be considered as one single first violation, and the penalty or disciplinary measure imposed shall be based on the violation that carries the more severe sanction.
- 5.2** Where a Person, based on the same Doping Control, is found to have committed an anti-doping rule violation under Article 7.7.1 below of these IBU Disciplinary Rules and another under Article 7.7.2 below of these IBU Disciplinary Rules, the Athlete shall be considered to have committed a single rule violation, but the sanction imposed shall be based on the Prohibited Substance or Prohibited Method that carries the most severe sanction.
- 5.3** Where a Person is found to have committed two separate anti-doping rule violations, one involving Article 7.7.1, and the other involving Article 7.7.2 below, the ban period imposed for the second offence shall be at a minimum two years and at a maximum three years. Any Person found to have committed a third offence involving any such combination shall receive a lifetime ban.

ARTICLE 6 AUTOMATIC INVALIDATION OF RESULTS

- 6.1** Any presence of a Prohibited Substance or its Metabolites or Markers in an Athlete's bodily Specimen during a competition automatically leads to invalidation of all results obtained at the respective event (with all its consequences, including forfeiture of any medals, points and prizes), irrespective of any penalty that is applied. The invalidation of results with all its consequences shall apply to all competitions.
- 6.2** Any presence of a Prohibited Substance or its Metabolites or Markers in a Relay team member's bodily Specimen during a competition automatically leads to invalidation of all results of the Relay team obtained at the respective competition (with all its consequences, including forfeiture of any medals, points and prizes), irrespective of any penalty that is applied.

ARTICLE 7 PENALTIES

Penalties that may be imposed are:

- 7.1 Reprimands**
A Reprimand shall be imposed in the case of:
- jeopardizing or defaming the honor or reputation of the IBU or its interests;
 - insulting the IBU, its Organs, its members, the organs of its members or their affiliates and relatives;
 - violations of rules for which there is no penalty or for which there is not an expressly stated more severe penalty;
 - as a minimum penalty for Athletes who can establish that the Use of any Specified Substance on the WADA Prohibited List was not intended to enhance sport performance, as a replacement of the ban period found in article 7.7.1 below.
- 7.2 Start Prohibition**
An Athlete or team shall be prohibited from starting for:
- violation of the eligibility requirements in article 1.4 of the IBU Event and Competition Rules;
 - not meeting the required conditions and the qualification criteria in article 1.5 of the IBU Event and Competition Rules;
 - appearing for start with material, equipment, clothing or advertising not in compliance with Article 4.2.2.4 of the IBU Event

and Competition Rules or Annex A (the IBU Material Catalogue) to those Rules, or with the IBU Rules for Advertising;

- appearing for start with the wrong start number, or no start number, due to a mistake made by the Athlete or his team;
- violating the rules regarding official training, zeroing, warm-up and/or ski testing.

The prohibition applies for the competition in which the violation occurred, or the next competition, as applicable.

7.3 One Minute Penalty

A time penalty of one minute shall be imposed on Athletes or teams for:

- not giving way at the first request by an overtaking Athlete;
- committing a very minor violation of the principles of fair play or the requirements of sportsmanship.

7.4 Two Minute Penalty

A time penalty of two minutes shall be imposed on Athletes or teams for:

- every penalty loop, as a result of shot-penalties, not done immediately after each prone or standing shooting by an Athlete;
- using the skating technique (one or both legs sideways) in the Relay or Mass Start Competition or in a group start, in the prepared start tracks after the start line;
- every round not fired if the Athlete recommences skiing before he has fired all five shots in an Individual, Sprint, Pursuit or Mass Start competition, or all eight shots in a Relay competition, having not hit all targets;
- committing a minor violation of the principles of fair play or the requirements of sportsmanship.

7.5 Disqualification

An Athlete or team shall be disqualified for:

- taking part in a competition for which he or she is not eligible;
- violating Article 1.4 of the IBU Event and Competition Rules "Eligibility Rules for Competitors and Teams";
- taking part in a competition under presence of any Prohibited Substance or its Metabolites or Markers in their body, or being a member of a Relay team of which a member, or members, are found having any Prohibited Substance or its Metabolites or Markers in their body in the competition;

- d. evading a Doping Control when ordered to attend;
- e. receiving prohibited assistance as defined in Article 1.8.2 of the IBU Event and Competition Rules from a member of his team staff or non-competing Athletes of his team;
- f. using equipment, rifle or clothing not in conformity with IBU rules, including carrying unauthorized advertising, at an IBU event or competition;
- g. avoiding start or finish inspections
- h. taking part in a competition with skis or rifle not correctly marked;
- i. modifying equipment, rifle or clothing, which has been inspected and marked at start inspection, in a prohibited way;
- j. participation in a competition with a start number or start number sequence color which has not been assigned to him by the competition start list, regardless of whether this is deliberate or due to a mistake made by him or by his team;
- k. deviating from the marked trail, or skiing a wrong trail, thus gaining a time advantage for himself or his team, or skiing the course loops in a wrong sequence or in the wrong direction;
- l. using means of propulsion other than skis, poles and his own muscular force;
- m. not carrying his rifle while skiing during the competition, and for not carrying the rifle on the course, when it is not damaged, with the barrel pointing up;
- n. hindering another competitor on the course or at the shooting range by serious obstruction;
- o. exchanging both skis during the competition;
- p. accepting unauthorized assistance from any person when repairing equipment, or receiving assistance other than authorized;
- q. for applying any substances during a competition intended to change the glide performance of his skis;
- r. firing more than five rounds in any shooting bout of an Individual, Sprint, Pursuit or Mass Start competition or more than eight rounds in a Relay, Mixed Relay or Super Sprint competition;
- s. remaining in an incorrect shooting position or incorrect position in the shooting lane after having been warned;
- t. failing to shoot in the correct sequence of positions;

- u. using a second magazine instead of hand loading lost rounds, replacement rounds for misfires, or spare rounds individually;
- v. violating any shooting safety regulations as defined in Article 8.5 of the IBU Event and Competition Rules;
- w. exchanging his rifle for another rifle, after starting, in any other location than the shooting range;
- x. committing a serious violation of the principles of fair play or the requirements of sportsmanship.

7.6 Suspension

7.6.1. In the case of a blood test showing haemoglobin values exceeding 17.5 g/dl for male Athletes and 16 g/dl for female Athletes, the Athletes in question will be suspended for health reasons with immediate effect from the respective competition and not be readmitted to a following IBU competition until a blood re-test shows haemoglobin values below 17.5 g/dl for male and 16 g/dl for female Athletes. A blood re-test can be performed not earlier than five days after the initial blood test showing exceeded haemoglobin values. A blood re-test must take place at the latest before the next IBU event, as long as the period between the initial blood test showing exceeded haemoglobin values and the next event exceeds five days.

7.6.2. If, after the end of a protest deadline of a competition, an Athlete is found guilty of having grossly violated the IBU Rules, the Competition Jury of the competition concerned may suspend the Athlete from the next competition. In case of a particularly gross violation, the Executive Board may extend the suspension to more than one competition and up to a maximum of 15 consecutive competitions of the ongoing World Cups and World Championships.

7.7 Ban

7.7.1 A ban of two years will be imposed on Athletes who are found having violated Articles 1.2.2 (Presence of a Prohibited Substance or its Metabolites or Markers), 1.2.3 (Use or Attempted Use of a Prohibited Substance or Prohibited Method), 1.2.4 (Refusing or failure to submit to Sample collection), 1.2.6 (Tampering with Doping Control) or 1.2.7 (Possession of Prohibited Substances and Methods) of the IBU Anti-Doping Rules, in or out of competition. Athletes who are found of having been doped in such a way a second time shall be banned for life from IBU competitions.

- 7.7.2** A ban of a maximum of one year shall be imposed on Athletes who can establish that the Use of any Specified Substance on the WADA Prohibited List was not intended to enhance sport performance, as a replacement of the ban period found in Article 7.7.1 above. Athletes who are found having used one of these substances a second time will be banned for a two-year period. Any other additional offence of this kind will result in a lifetime ban from IBU competitions.
- 7.7.3** A ban of a minimum three months and at a maximum two years shall be imposed on Athletes belonging to the IBU Registered Testing Pool who are found having violated Articles 4.9 and 4.14 of the IBU Anti-Doping Rules (Whereabouts violation), after having been once fined according to Article 7.9.2 below.
- 7.7.4** A ban of a minimum of four years up to lifetime shall be imposed on Athletes found having violated Articles 1.2.8 (Trafficking) or 1.2.9 (Administration of a Prohibited Substance or Prohibited Method) of the IBU Anti-Doping Rules. For Athletes found having violated any of these provisions, ignorance of the nature or composition of the Prohibited Substances or the nature or effects of the methods in question shall not constitute any extenuating circumstances or grounds for exemption from punishment. Any such anti-doping rule violation involving a Minor shall be considered a particularly serious violation. Athletes found having committed any such anti-doping rule violation shall also be excluded from any function within the IBU for life. In addition, any such violation that also violates non-sporting laws or regulations may be reported to the competent administrative authorities, professional associations/directorate or judicial authorities.
- 7.7.5** The ban shall begin on the day when the urine sample/blood sample on which the ban is based had been collected or on the day when the ban was imposed. The competent Body will reach its ruling considering the requirements of fairness to the other Athletes. The ban will include both the World Championships or, if applicable, the Olympic Winter Games that might take place during this time. The lifetime ban will begin on the day of the offense. In the case of a ban based on Article 7.7.1 above, the Person will lose all sport-related financial support or other sport-related benefits from the IBU and the respective Member Federation. An Athlete banned for a period longer than four years may, after completing four years of the

ban period, participate in local sports events in a sport other than those sports subject to the jurisdiction of the IBU and its Member Federations, but only so long as the local sport competition is not at a level that could otherwise qualify such Person directly or indirectly to compete in or accumulate points toward a national championship or international competition.

- 7.7.6** As a condition to regaining eligibility at the end of a specified ban period, an Athlete must, during any period of Ineligibility, make himself available for Out-of-Competition Testing by the IBU, the applicable Member Federation, and any other anti-doping organization having testing jurisdiction, and must provide current and accurate whereabouts information as provided in Articles 4.9 - 4.11 of the IBU Anti-Doping Rules. If an Athlete subject to a ban period retires from sport and is removed from Out-of-Competition Testing pools and later seeks reinstatement, the Athlete shall not be eligible for reinstatement to his former Status until the Athlete has notified the IBU and the applicable Member Federation and has been subject to Out-of-Competition Testing for a period of time equal to the period set forth in Article 4.10 of the IBU Anti-Doping Rules or the ban period remaining as of the date the Athlete had retired. During such remaining ban period, a minimum of two tests must be conducted on the Athlete with at least three months between each test. The respective Member Federation shall be responsible for conducting the necessary tests, but tests by any anti-doping organization may be used to satisfy the requirement. The results of such tests shall be reported to the IBU. In addition, immediately prior to the end of the ban period, an Athlete must undergo an Out-of-Competition test by the IBU. Once an Athlete's ban period has expired, and the Athlete has fulfilled the conditions of reinstatement to his former status, then the Athlete will automatically become re-eligible and no application by the Athlete or by the Athlete's National Federation will be necessary.

- 7.7.7** No ban may be imposed for a violation of the IBU Anti-Doping Rules unless the respective procedure is commenced within eight years from the date the violation occurred.

- 7.8 Refusal of Doping Control**
Athletes, who have been selected for Doping Control and refuse to undergo these tests or examinations will be treated in such a way as

if evidence of doping, or of exceeded haemoglobin values in the blood would have been established. In these cases, culpability will be legally assumed.

7.9 Fine

7.9.1 In the case of a gross violation of the IBU Constitution, the Rules of the IBU, of decisions made by IBU Bodies or in the case of endangering or damaging the reputation or the interests of the IBU, a fine can be imposed amounting from 70 € to 10,000 €.

7.9.2 Athletes belonging to the IBU Registered Testing Pool that infringe their duty under the IBU Anti-Doping Rules to timely report their whereabouts will be fined from 70 € to 500 €.

7.9.3 The fines will become the property of the IBU.

7.10 The penalties stipulated in Articles 7.3 – 7.5 can only be imposed before the publication of the Final Results.

ARTICLE 8 DISCIPLINARY MEASURES AND SANCTIONS ON MEMBER FEDERATIONS

These disciplinary measures will be imposed on persons listed under Article 3.2 above:

8.1 Reprimand

A reprimand will be given for insignificant offences against the Constitution and Rules of the IBU or against decisions of the Organs of the IBU as well as for endangerment or damage done to the reputation or interests of the IBU.

8.2 Fines

8.2.1 Fines will be imposed on those who seriously violate the IBU Constitution, the IBU Rules or decisions of the Organs or other competent Bodies of the IBU, as well as on those who jeopardize or damage the interests or the reputation of the IBU. The fine may be from 70 € to 10,000 €, depending on the seriousness of the violation as determined by the IBU Executive Board.

8.2.2 A Member Federation that does not inform the Medical Committee of the IBU in writing about the use of admissible substances which must be registered before the start of a competition will be sentenced to a fine of 350 € if the use is revealed at a doping

control by the laboratory. The same fine will be imposed on a Member Federation that does not fulfil its obligations under Article 3 of the Anti-Doping Rules or that does not coordinate the reporting of the whereabouts of its Athletes belonging to the IBU Registered Testing Pool or who have been selected for Target Testing. Furthermore, a fine of the sum of 350 € will also be imposed on a Member Federation if more than one Athlete or more than one Person from this Member Federation commits a violation of the IBU Anti-Doping Rules during one and the same year.

8.2.3 The fines will become the property of the IBU.

8.2.4 A Member Federation, an official of which is found guilty of having counselled, permitted or contributed to the use of a Prohibited Substance or Prohibited Method as specified in the IBU Anti-Doping Rules at a World Cup or World Championships will lose any financial contribution and any financial support by the IBU for that particular and all other events for the period of one year.

8.2.5 A Member Federation is obligated to reimburse the IBU for all costs, including but not limited to laboratory fees, hearing expenses and travel expenses related to the violation of the IBU Anti-Doping Rules by an Athlete or Person under Article 3.2 above affiliated with this Member Federation.

8.2.6 An Organising Committee which violates its obligations according to the IBU Event and Competition Rules and IBU Anti-Doping Rules will be fined the sum of 350 €.

8.3 Ban

8.3.1 Any person under Article 3.2 above and/or persons hired to organize IBU events found to have violated or cooperated in violating Articles 1.2.6 (Tampering with Doping Control) or 1.2.7 (Possession of Prohibited Substances and Methods) of the IBU Anti-Doping Rules by Athletes – with or without the knowledge of the Athlete – in or out of competition will be banned from IBU competitions for two years for the first violation and for life for the second violation.

8.3.2 Any person under Article 3.2 above and/or persons appointed to organize IBU events found having violated Articles 1.2.2 (Presence of a Prohibited Substance), 1.2.3 (Use or Attempted Use), 1.2.8 (Trafficking) or 1.2.9 (Administration of a Prohibited Substance or

Prohibited Method) of the IBU Anti-Doping Rules shall be banned for a minimum of four years up to life time from participation in any IBU sports organization, IBU Body, IBU activity or IBU event in any capacity whatsoever. Any attempt at such a violation shall be penalized in the same manner as the act itself. For persons found having committed such a violation, ignorance of the nature or composition of the Prohibited Substances or the nature and effects of the methods in question shall not constitute any attenuating circumstances or grounds for exemption from punishment. Any such violation involving a Minor shall be considered a particularly serious violation, and, if committed by Athlete Support Personnel, shall result in a ban for lifetime. In addition, any such violation which also violates non-sporting laws or regulations, may be reported to the competent administrative authorities, professional associations/directorate or judicial authorities.

8.3.3 The ban period shall start on the date of the decision imposing the ban. In the case of a ban based on Article 8.3.1 above, the Person will lose all sport-related financial support or other sport-related benefits from the IBU and the respective Member Federation.

8.3.4 No ban may be imposed for a violation of the IBU Anti-Doping Rules unless the respective procedure is commenced within eight years from the date the violation occurred.

8.4 Removal from a Function

Persons listed in Article 3.2 above who seriously violate the IBU Constitution, the IBU Rules or decisions made by the IBU Executive Board or other competent Bodies of the IBU may be removed from their IBU function for the remaining period of elected or appointed service and may be further restricted from future periods of elected or appointed service up to a lifetime ban.

ARTICLE 9 ORGANS AND COMPETENCY

9.1 Penal and disciplinary power are exercised in the first instance by the Competition Jury and the Executive Board of the IBU.

9.2 The Executive Board of the IBU is responsible for imposing disqualification in doping matters, for suspensions, except those according to Article 7.6.2, sentence 1, for bans and fines as well as removal from a function. The removal of a person elected by the

Congress from his function requires confirmation by the next Congress. The Competition Jury is responsible for imposing all other penalties and disciplinary measures.

9.3 Appeals against penalty and disciplinary decisions of the Competition Jury may be lodged with the Jury of Appeal; appeals against penalty and disciplinary decisions of the Executive Board or Congress may be lodged with the IBU Court of Arbitration.

ARTICLE 10 JURY OF APPEAL

10.1 The Jury of Appeal shall consist of five members and shall be newly constituted for each event. The chair will be held by a member of the IBU Executive Board who is appointed by this Executive Board for each IBU event of a competition season. The other members of the Jury of Appeal must also be members of the Executive Board, as long as there are enough present at the event. At competitions where there are not enough Executive Board members available, all the other members shall be team captains and coaches of the teams participating in the Team Captains Meeting. This applies for the Olympic Winter Games, World Championships, Junior and Youth World Championships and Biathlon World Cups.

10.2 The four members of the Jury of Appeal that are not the Chairperson shall be elected not later than on the day of the Team Captains Meeting - which shall be held on the day before the first Official Training takes place, and before the selection of the Competition Jury - from among the Executive Board members present, or from among the team captains and coaches of the teams participating in the Team Captains Meeting. The Chairperson shall chair the election of the Jury of Appeal. The members of the Jury of Appeal must not be a competition official or a member of the Competition Jury at the same time. For the election each Member Federation can cast only one vote.

10.3 In matters presented to the Jury of Appeal that concern a nation of which the Chairperson or a member of the Jury of Appeal is a citizen, or for which he works, this member shall be considered prejudiced and shall not have the right to vote. If the Chairperson is considered prejudiced, another member of the IBU Executive Board shall handle the matter in question or, if no other member of the

Executive Board is present, the oldest member of the Jury of Appeal shall take the chair.

- 10.4** For the election procedure and for decisions to be made, Article 2.3 of the IBU Event and Competition Rules shall apply.

ARTICLE 11 IBU COURT OF ARBITRATION

- 11.1** The IBU Court of Arbitration as an independent institution shall consist of 3 arbitrators, of whom at least the chairperson must be a qualified judge or have an equivalent juridical qualification.

11.2 **Seat**

Each member of the IBU shall have the right to nominate two arbitrators who will form a list of arbitrators from which the IBU Court of Arbitration will be assembled for each individual case. The nominations for arbitrators are to be sent by registered mail to the Secretary General of the IBU Court of Arbitration. The IBU Legal Committee shall elect the SG from among its members. The SG shall function as a depository for the list of arbitrators and shall inform the IBU Member Federations every year by 1 September of the current names on the list.

- 11.3** The appellant will select one arbitrator, the Executive Board will appoint the other.

- 11.4** Within ten days of the appointment of the second arbitrator, both arbitrators have to agree on a Chairperson. If the nomination of a Chairperson does not occur during the 10-day time limit or if the two arbitrators cannot agree on a time limit within which they will undertake the election of the Chairperson then the Chairperson will be appointed by the President of the CAS in Lausanne on the motion of a party.

- 11.5** In the case of one of the arbitrators being unable to or prevented from presiding, his successor will be appointed according to the same procedure as the withdrawing arbitrator.

ARTICLE 12 PROCEDURE FOR THE COMPETITION JURY

- 12.1** The composition of the Competition Jury is stipulated in Article 2.3.2. of the IBU Event and Competition Rules.

- 12.2** The Competition Jury shall impose penalties and disciplinary measures following a report from the TD(s), IRs, competition officials, on the basis of observations by its members or as a consequence of protests.

- 12.3** Before a Competition Jury can impose a penalty, the Athlete affected and/or his team captain must be given a hearing, as far as possible and feasible.

- 12.4** The Competition Jury shall be independent. The Competition Jury shall not be restricted in the admission or evaluation of evidence.

- 12.5** If the Competition Jury does not uphold a submitted protest under Article 10 of the IBU Event and Competition Rules, an appeal may be lodged with the Jury of Appeal.

ARTICLE 13 PROCEDURE FOR THE EXECUTIVE BOARD

- 13.1** Before fines or a removal from a function are imposed, a hearing of the person concerned must take place in the ordinary course of the next regular meeting of the Executive Board. With regard to the procedure, Article 7 of the IBU Constitution shall apply. The decision is to be communicated to the person concerned in writing.

- 13.2** The decision on suspensions and bans must be made during an extraordinary meeting of the Executive Board, which has to take place within two weeks of the disclosure of a positive B-test result to the Secretary General.

- 13.3** The person concerned and his National Federation have to be granted a legal hearing and access to the services of an advisor and interpreter. The person concerned shall have the right to present evidence, including the right to call and question witnesses. The Board shall not be restricted in the admission or evaluation of evidence.

- 13.4** The decision, with the reasons, must be delivered in writing to the person concerned within 14 days of when it is passed.

- 13.5** The costs that accrue from the extraordinary session of the Executive Board and from the B-test examination shall be borne in the case of a conviction by the person concerned or alternatively by the Federation concerned.

ARTICLE 14 APPEAL PROCEEDINGS FOR THE JURY OF APPEAL

- 14.1** The time limit for lodging an appeal against the imposition of a penalty or a disciplinary measure is 1 hour. This time limit shall begin – before and during the competition – from the notification of the Competition Jury's decision, and after a competition beginning from the publication of the Final Results.
- 14.2** The Jury of Appeal shall meet immediately after this time limit and make its decision as soon as possible, in any case before 24:00 hours midnight of the same day.
- 14.3** The appeal is to be lodged in writing with the Chairperson of the Jury of Appeal at the Competition Office. The appeal must be accompanied by a bond of 75 € to be left at the Competition Office, which will be forfeited to the IBU if the appeal is denied.
- 14.4** The Chairperson of the Competition Jury must present the reasons for its decision to the Jury of Appeal.
- 14.5** The person concerned is to be given a legal hearing and an access to the services of an adviser and interpreter. The decision is to be submitted in writing and be kept at the premises of the IBU.
- 14.6** The appeal will be denied in the event of the non-appearance of the appellant.
- 14.7** The Jury of Appeal shall not be restricted in the admission or evaluation of evidence.
- 14.8** The decisions of the Jury of Appeal may not be challenged.

ARTICLE 15 APPEAL PROCEEDINGS FOR THE IBU COURT OF ARBITRATION

- 15.1** The appellant must lodge his appeal with the IBU Court of Arbitration in writing by registered letter to the Secretary General of the IBU Court of Arbitration within twenty-one days after receipt of the relevant decision. Within ten days from notification of the decision, such party shall have the right to request a copy of the file which the Executive Board used as reference from the IBU Executive Board. If such a request is made within the ten-day period, then the party making such request shall have twenty-one days from receipt of the file to file an appeal to the IBU Court of Arbitration. All claims must

briefly set out their nature and the facts relating thereto and concurrently appoint an arbitrator. The Secretary General of the IBU Court of Arbitration must inform the other party of the claim without delay.

- 15.2** The Executive Board must advise of its appointment of an arbitrator within 1 month after the receipt of this letter, including to the appellant. If the Executive Board fails to make this appointment, the appellant may seek the appointment of the second arbitrator by the Secretary General of the IBU Court of Arbitration.
- 15.3** Arbitrators are bound in their decisions by the IBU Constitution, IBU Rules, IBU Event and Competition Rules, and IBU Anti-Doping Rules as well as by the provisions of substantive law of the Republic of Austria. To the extent not provided otherwise by the Constitution and Rules of the IBU, the general precepts of Austrian civil procedure law shall apply to the arbitration proceedings.
- 15.4** According to the circumstances, the arbitrators should strive to bring about an amicable settlement, except in the cases of Article 10.2. c. and d. of the IBU Constitution. In urgent cases, the Chairperson of the IBU Court of Arbitration is authorized to determine provisional or conservatory measures to guarantee due process.
- 15.5** The IBU Court of Arbitration shall make its ruling after an oral hearing, as far as possible within a time limit of three months of being constituted.
- 15.6** In the oral hearings, the circumstances of the dispute shall be determined by hearing the appellant, a representative of the Executive Board, any witnesses and any experts appointed by the IBU Court of Arbitration.
- 15.7** Further evidence may be admitted independently of the motions of the parties.
- 15.8** The appellant and the representative of the Executive Board shall be given the opportunity to be present during the examination of witnesses and comment on their testimony.
- 15.9** Oral hearings shall be open to IBU members.
- 15.10** The non-appearance of a party shall not hinder the execution of the procedure.

- 15.11** The appellant and the Executive Board may avail themselves of the assistance of a legal adviser and an interpreter at any stage of the proceedings.
- 15.12** Appeals against decisions of the Executive Board will not have suspensive effect.
- 15.13** The IBU Court of Arbitration's decision, with reasons in writing, is to be transmitted to both parties by registered mail within 14 days of its issue.
- 15.14** The IBU Court of Arbitration will also rule on the costs of the proceedings. These can be split among the parties or imposed in full upon one party only. Upon filing the arbitration request, the claimant shall pay a fee of 350 € without which the IBU Court of Arbitration shall not proceed. Upon formation of the Court, the Secretary General of the IBU Court of Arbitration shall set – subject to later changes – the amount and the method for an advance payment of court costs. Each party shall advance the costs for one arbitrator and half of the costs of the Chairperson as well as the costs for its own witnesses, experts and interpreters.
- 15.15** Decisions of the IBU Court of Arbitration are final and shall have no recourse to appeal, with the exception of decisions on doping matters and in matters of Article 10.2 d. of the IBU Constitution. Regarding doping matters and matters of Article 10.2 d. of the IBU Constitution, an appeal can be made to the CAS (Court of Arbitration for Sports) in Lausanne.

ARTICLE 16 EXEMPTION FROM LIABILITY

The competent Organs and their members cannot be made liable for claims arising out of the enforcement of the present Disciplinary Rules.

ARTICLE 17 ENTRY INTO FORCE

The Disciplinary Rules of the IBU became effective as of 1 July 1994 and were amended by the 1996, 1998, 2000, 2002, 2004 Congresses and provisionally amended pending confirmation by the 2006 Congress in June 2006 by the Executive Board. The last amended version became effective as of 15 June 2006. The confirmation by the Congress took place on 3 September 2006.



IBU EVENT AND COMPETITION RULES

Adopted by the 1998 IBU Congress
with amendments by the 2000,
2002, 2004 and 2006 Congresses.

LIST OF CONTENTS

1. GENERAL REGULATIONS

1.1. Application 4

1.2. Classes of Competitors 4

1.3. Types of Competitions 5

1.4. Eligibility Rules for Competitors and Teams 11

1.5. Registration and Entry 12

1.6. Draw and Assignment of Start Numbers 14

1.7. Team Captains Meetings 18

1.8. Prohibitions and Sanctions for Non-Competing Persons 19

1.9. Awards 20

2. ORGANIZATIONS AND APPOINTMENTS

2.1. General 20

2.2. The Organizing Committee 20

2.3. The Competition Jury 21

2.4. Technical Delegates 23

2.5. International Referees 24

3. COMPETITION VENUES AND FACILITIES

3.1. General 25

3.2. Start and Warm-up Areas 27

3.3. Course and Associated Sections 29

3.4. Shooting Range 32

3.5. Finish Area 36

3.6. Team Wax Cabins 37

3.7. Competitor Waiting Rooms 38

4. COMPETITION EQUIPMENT AND CLOTHING FOR EVENTS

4.1. General Rules 38

4.2. Inspections of Equipment and Clothing 38

5. TRAINING AND ZEROING

5.1. General 41

5.2. Official Training 42

5.3. Rifle Zeroing 42

5.4. Warm-up on the Course 44

5.5. Ski Testing 44

6. START REGULATIONS

6.1. Start Types and Intervals 44

6.2. Starting Positions and Starts 45

6.3. Start Signals 46

6.4. Start Time, Early Start, Late Start and False Start 47

6.5. Start Numbers 49

6.6. Weather Conditions 50

7. SKIING REGULATIONS

7.1. General 52

7.2. Obstruction 53

7.3. Exchanging Equipment, Repairs, Assistance 53

8. SHOOTING REGULATIONS

8.1. General 54

8.2. Specific Shooting Rules for Types of Competitions 54

8.3. Shooting Positions 55

8.4. Shooting Aids 56

8.5. Safety Regulations 56

8.6. Misfires, Lost Rounds/Magazines and Damaged Rifles 57

8.7. Target Errors and Malfunctions 59

9. THE FINISH, COMPETITION TIME AND RESULTS

9.1. The Finish 60

9.2. Competition Time 60

9.3. Timing Systems 62

9.4. The Competition Results 62

10. PROTESTS

10.1. General 64

10.2. Protest Types and Conditions 65

11. PENALTIES 65

12. WORLD CHAMPIONSHIPS – EVENT RULES

12.1. General Regulations 65

12.2. Bids to Host and Appointment of Hosts 66

12.3. Event Schedule and Program 66

12.4. Progress Reports 67

12.5. Information Bulletins and Invitations 67

12.6. Participation 67

12.7. Awards 69

12.8. Leader Start Numbers 70

13.	THE OLYMPIC WINTER GAMES – EVENT RULES	
13.1.	Rules	70
13.2.	Schedule and Program	70
14.	CONTINENTAL CHAMPIONSHIPS AND CONTINENTAL CUPS – EVENT RULES	
14.1.	Continental Championships	71
14.2.	Continental Cups	72
15.	WORLD CUP - EVENT RULES	
15.1.	General Regulations	72
15.2.	WC Annual Scheduling	73
15.3.	Bids to Host an Event and Appointment of Hosts	73
15.4.	WC Program	74
15.5.	Invitations	74
15.6.	Participation	74
15.7.	World Cup Leader Start Numbers	76
15.8.	World Cup Scoring System.....	77
15.9.	Awards	79
16.	ENTRY INTO FORCE	81

LIST OF TABLES

Table 1 – Competition Specifications – Skiing and Shooting	7
Table 2 – Wind-chill Temperature Equivalency Chart	51

ANNEXES

ANNEX A	MATERIAL CATALOGUE
ANNEX B	DUTIES OF THE COMPETITION JURY, TECHNICAL DELEGATES AND INTERNATIONAL REFEREES
ANNEX C	TRAINING AND LICENSING OF TECHNICAL DELEGATES AND INTERNATIONAL REFEREES
ANNEX D	RULES FOR CONTINENTAL CHAMPIONSHIPS
ANNEX E	RULES FOR CONTINENTAL CUP EVENTS
ANNEX F	RULES FOR SUMMER BIATHLON

1. GENERAL REGULATIONS

1.1 APPLICATION

These Rules must be applied fully at World Championships (WCH), Youth/Junior World Championships (Y/J WCH) and World Cups (WC). At Continental Championships (CCH) and Continental Cups (CC) these rules must be applied in principle and as far as they are applicable. In other international events these rules shall be applied accordingly unless changes have been notified in separate rules or in the invitation. At the Olympic Winter Games (OWG) these rules must be used accordingly, except when otherwise stipulated by the IOC.

1.2 CLASSES OF COMPETITORS

The following classes are authorized for IBU competitions:

1.2.1 Men and Women

Male and female competitors who have completed their 21st year of life at the cut-off-date 31 December shall be called Men and Women respectively and henceforth shall start only in Men's and Women's competitions according to gender for the season starting on 1 November of the same year.

1.2.2. Junior Men and Junior Women

Male and female competitors who have completed their 19th year of life at the cut-off-date of 31 December shall be called Junior Men and Junior Women respectively and shall start only in Junior Men's and Junior Women's competitions according to gender for the season starting on 1 November of the same year. Separate competitions shall be organized for them. However, Junior Men shall be permitted to participate in Men's and Junior Women in Women's competitions respectively, according to gender.

1.2.3. Youth Men and Youth Women

Competitors who have not yet reached Junior Men's or Junior Women's age as defined above shall be Youth Men or Youth Women respectively, and separate competitions shall be organized for them. Youth Men shall be permitted to take part in Men's and Junior Men's competitions and Youth Women shall be permitted to take part in Women's and Junior Women's competitions. However, at an event in the Individual, Sprint and Pursuit competition they may start in only one and the same class of competitor. Moreover, Youth may only participate in one relay competition at the Y/JWCH.

1.3 TYPES OF COMPETITIONS

The following types of competitions shall be authorized at IBU events:

1.3.1 Men

- a. 20 km Individual;
- b. 10 km Sprint;
- c. 12.5 km Pursuit;
- d. 4 x 7.5 km Relay;
- e. 15 km Mass Start;
- f. 6 km Super Sprint including 3.6 km Super Sprint Qualification.

1.3.2 Women

- a. 15 km Individual;
- b. 7.5 km Sprint;
- c. 10 km Pursuit;
- d. 4 x 6 km Relay;
- e. 12.5 km Mass Start;
- f. 4 km Super Sprint including 2.4 km Super Sprint Qualification.

1.3.3 Men and Women/Mixed Relay

2 x 6 km Women + 2 x 7.5 km Men.

1.3.4 Junior Men

- a. 15 km Individual;
- b. 10 km Sprint;
- c. 12.5 km Pursuit;
- d. 4 x 7.5 km Relay;
- e. 12.5 km Mass Start;
- f. 6 km Super Sprint including 2.4 km Super Sprint Qualification.

1.3.5 Junior Women

- a. 12.5 km Individual;
- b. 7.5 km Sprint;
- c. 10 km Pursuit;
- d. 3 x 6 km Relay;
- e. 10 km Mass Start;
- f. 4 km Super Sprint including 2.4 km Super Sprint Qualification.

1.3.6 Youth Men

- a. 12.5 km Individual;
- b. 7.5 km Sprint;
- c. 10 km Pursuit;
- d. 3 x 7.5 km Relay;
- e. 10 km Mass Start
- f. 4 km Super Sprint including 2.4 km Super Sprint Qualification.

1.3.7 Youth Women

- a. 10 km Individual;
- b. 6 km Sprint;
- c. 7.5 km Pursuit;
- d. 3 x 6 km Relay;
- e. 7.5 km Mass Start
- f. 4 km Super Sprint including 2.4 km Super Sprint Qualification.

1.3.8 Competition Specifications

The following Table 1 and the appended notes set out the skiing and shooting specifications for IBU classes of competitors and the types of competitions, and shall apply for all IBU events:

**TABLE 1 – COMPETITION SPECIFICATIONS –
SKIING AND SHOOTING**

1 Class of Competitor	2 Course Length and Competition Type	3 Standard Start Types and Intervals	4 Ski Loops	5 Shooting Bouts and Shot Penalty 5 Rounds per Bout except Relay	6 Distance between and Location of Shooting Bouts	7 Total Climb	
MEN	20 KM INDIVIDUAL	Single, 30 sec, 1 minute	5	P, S, P, S - 1 minute	4 km - 4, 8, 12, 16 km	600 - 800 m	
	10 KM SPRINT	Single, 30 sec, 1 minute	3	P, S - 150 m	3.3 km - 3.3 and 6.6 km	300 - 400 m	
	12.5 KM PURSUIT	Pursuit	5	P, P, S, S - 150 m	2.5 km - 2.5, 5, 7.5, 10 km	350 - 500 m	
	15 KM MASS START	Simultaneous	5	P, P, S, S - 150 m	3 km - 3, 6, 9, 12 km	400 - 600 m	
	4 x 7.5 KM RELAY	Simultaneous and Tag	3	P, S (each) + 3 Spare Rounds per Bout - 150 m	2.5 km - 2.5 and 5	200 - 300 m	
	2.4 - 3.6 KM SUPER SPRINT QUALIFICATION	Single, 15 sec	3	P, S (each) + 3 Spare Rounds per Bout - Penalty = Disqualification	800 m - 2400 m	45 - 75 m	
	4 - 6 KM SUPER SPRINT FINAL	Simultaneous	5	P, P, S, S, (each) + 3 Spare Rounds per Bout - Penalty = Disqualification	800 m - 4800 m	60 - 125 m	
	MIXED RELAY 2 x 6 KM (W) 2 x 7.5 KM (M)	Simultaneous and Tag	3	P, S (each) + 3 Spare Rounds per Bout - 150 m Penalty	2 km - 2 and 4 (W) 2.5 km - 2.5 and 5 (M)	150-240 m (W) 200-300 m (M)	
	WOMEN	15 km INDIVIDUAL	Single, 30 sec, 1 minute	5	P, S, P, S - 1 minute	3 km - 3, 6, 9, 12 km	400 - 600 m
		7.5 KM SPRINT	Single, 30 sec, 1 minute	3	P, S - 150 m	2.5 km - 2.5 and 5 km	200 - 300 m
10 KM PURSUIT		Pursuit	5	P, P, S, S - 150 m	2 km - 2, 4, 6, 8 km	200 - 400 m	
12.5 KM MASS START		Simultaneous	5	P, P, S, S - 150 m	2.5 km - 2.5, 5, 7.5, 10 km	350 - 500 m	
2.4 - 3.6 KM SUPER SPRINT QUALIFICATION		Single, 15 sec	3	P, S (each) + 3 Spare Rounds per Bout - Penalty = Disqualification	800 m - 2400 m	45 - 75 m	
4 - 6 KM SUPER SPRINT FINAL		Simultaneous	5	P, P, S, S, (each) + 3 Spare Rounds per Bout - Penalty = Disqualification	800 m - 4800 m	60 - 125 m	
4 x 6 KM RELAY		Simultaneous and Tag	3	P, S (each) + 3 Spare Rounds per Bout - 150 m	2 km - 2 and 4 km	150 - 240 m	

1 Class of Competitor	2 Course Length and Competition Type	3 Standard Start Types and Intervals	4 Ski Loops	5 Shooting Bouts and Shot Penalty 5 Rounds per Bout except Relay	6 Distance between and Location of Shooting Bouts	7 Total Climb	
JUNIOR MEN	15 KM INDIVIDUAL	Single, 30 sec, 1 minute	5	P, S, P, S - 1 minute	3 km - 3, 6, 9, 12 km	400 - 500 m	
	10 KM SPRINT	Single, 30 sec, 1 minute	3	P, S - 150 m	3.3 km - 3.3 and 6.6 km	300 - 400 m	
	12.5 KM PURSUIT	Pursuit	5	P, P, S, S - 150 m	2.5 km - 2.5, 5, 7.5, 10 km	350 - 500 m	
	12.5 KM MASS START	Simultaneous	5	P, P, S, S - 150 m	2.5 km - 2.5, 5, 7.5, 10 km	350 - 500 m	
	4 x 7.5 KM RELAY	Simultaneous and Tag	3	P, S (each) + 3 Spare Rounds per Bout - 150 m	2.5 km - 2.5 and 5 km	200 - 300 m	
	2.4 - 3.6 KM SUPER SPRINT QUALIFICATION	Single, 15 sec	3	P, S (each) + 3 Spare Rounds per Bout - Penalty = Disqualification	800 m - 2400 m	45 - 75 m	
	4 - 6 KM SUPER SPRINT FINAL	Simultaneous	5	P, P, S, S, (each) + 3 Spare Rounds per Bout - Penalty = Disqualification	800 m - 4800 m	60 - 125 m	
	JUNIOR WOMEN	12.5 KM INDIVIDUAL	Single, 30 sec, 1 minute	5	P, S, P, S - 1 minute	2.5 km - 2.5, 5, 7.5, 10 km	350 - 500 m
		7.5 KM SPRINT	Single, 30 sec, 1 minute	3	P, S - 150 m	2.5 km - 2.5 and 5 km	200 - 300 m
		10 KM PURSUIT	Pursuit	5	P, P, S, S - 150 m	2 km - 2, 4, 6, 8 km	200 - 350 m
10 KM MASS START		Simultaneous	5	P, P, S, S - 150 m	2 km - 2, 4, 6, 8 km	200 - 350 m	
3 x 6 KM RELAY		Simultaneous and Tag	3	P, S (each) + 3 Spare Rounds per Bout - 150 m	2 km - 2 and 4 km	150 - 250 m	
2.4 - 3.6 KM SUPER SPRINT QUALIFICATION		Single, 15 sec	3	P, S (each) + 3 Spare Rounds per Bout - Penalty = Disqualification	800 m - 2400 m	45 - 75 m	
4 - 6 KM SUPER SPRINT FINAL		Simultaneous	5	P, P, S, S, (each) + 3 Spare Rounds per Bout - Penalty = Disqualification	800 m - 4800 m	60 - 125 m	

1	2	3	4	5	6	7
Class of Competitor	Course Length and Competition Type	Standard Start Types and Intervals	Ski Loops	Shooting Bouts and Shot Penalty 5 Rounds per Bout except Relay	Distance between and Location of Shooting Bouts	Total Climb
YOUTH MEN	12.5 KM INDIVIDUAL	Single, 30 sec, 1 minute	5	P, S, P, S - 1 minute	2.5 km - 2.5, 5, 7.5, 10 km	350 - 500 m
	7.5 KM SPRINT	Single, 30 sec, 1 minute	3	P, S - 150 m	2.5 km - 2.5 and 5 km	200 - 300 m
	10 KM PURSUIT	Pursuit	5	P, P, S, S - 150 m	2 km - 2, 4, 6, 8 km	200 - 350 m
	10 KM MASS START	Simultaneous	5	P, P, S, S - 150 m	2 km - 2, 4, 6, 8 km	200 - 350 m
	3 x 7.5 KM RELAY	Simultaneous and Tag	3	P, S (each) + 3 Spare Rounds per Bout - 150 m	2.5 km - 2.5 and 5 km	200 - 300 m
	2.4 - 3.6 KM SUPER SPRINT QUALIFICATION	Single, 15 sec	3	P, S (each) + 3 Spare Rounds per Bout - Penalty = Disqualification	800 m - 2400 m	45 - 75 m
	4 - 6 KM SUPER SPRINT FINAL	Simultaneous	5	P, P, S, S, (each) + 3 Spare Rounds per Bout - Penalty = Disqualification	800 m - 4800 m	60 - 125 m
YOUTH WOMEN	10 KM INDIVIDUAL	Single, 30 sec, 1 minute	5	P, S, P, S - 1 minute	2 km - 2, 4, 6, 8 km	200 - 350 m
	6 KM SPRINT	Single, 30 sec, 1 minute	3	P, S - 150 m	2 km - 2 and 4 km	150 - 250 m
	7.5 KM PURSUIT	Pursuit	5	P, P, S, S - 150 m	1.5 km - 1.5, 3, 4.5, 6 km	200 - 300 m
	7.5 KM MASS START	Simultaneous	5	P, P, S, S - 150 m	1.5 km - 1.5, 3, 4.5, 6 km	150 - 240 m
	3 x 6 KM RELAY	Simultaneous and Tag	3	P, S (each) + 3 Spare Rounds per Bout - 150 m	2 km - 2 and 4 km	150 - 250 m
	2.4 - 3.6 KM SUPER SPRINT QUALIFICATION	Single, 15 sec	3	P, S (each) + 3 Spare Rounds per Bout - Penalty = Disqualification	800 m - 2400 m	45 - 75 m
	4 - 6 KM SUPER SPRINT FINAL	Simultaneous	5	P, P, S, S, (each) + 3 Spare Rounds per Bout - Penalty = Disqualification	800 m - 4800 m	60 - 125 m

Notes to Table 1

Height Difference (hd): the maximum permitted difference in altitude between the highest and lowest points on the competition course is to be 80 m for all competitions.

Maximum climb (mc): the maximum permitted height difference of an ascent without either a flat part or a descent of at least 200 m in length is to be 75 m for all competitions.

Column 1: Class of Competitor: according to these Rules.

Column 2: Course Length and Type of Competition: according to these Rules.

Column 3: Start Types and Intervals: the method by which the start is made and the interval between the starts of two consecutive competitors.

Column 4: Number of Ski Loops: course rounds to be skied by the competitor.

Column 5: Shooting Bouts and Shot Penalties: the number of shooting bouts the competitor must do and the shooting position to be used in the bout (P = Prone, S = Standing), the number of rounds the competitor must fire in each bout, and the automatic shot-penalty – 1 minute of added time or a 150 m penalty loop – imposed on a competitor for each target left standing after all rounds for the bout have been fired.

Column 6: Distance Between and Location of Shooting Bouts: the minimum distance between successive shooting bouts in the competition and the ski distances after which shooting must occur.

Column 7: Total Climb (tc): the total vertical ascent in the competition (the sum of all the ascents) for each competitor.

1.3.9 Specifications for Super Sprint

Super Sprint shall consist of a Qualification and a Final competition, which will take place on the same day.

1.3.10 Modifications and Other Types of Competitions

The IBU shall hold the right to modify existing competitions and to introduce new types of competitions into IBU events.

1.3.11 Event Programs

The schedule, sequence and types of competitions for IBU events shall be set by the IBU EB, on the recommendation of the TC.

1.3.12 Annual Schedule of Events

IBU events will be held annually as stated in the event rules or as directed by the EB. The yearly schedules will be published in the IBU Biathlon Calendar. NFs are requested to provide their national schedule of major events to the IBU Secretary General for publication in the IBU Biathlon Calendar not later than 30 July of each year.

1.4 ELIGIBILITY RULES FOR COMPETITORS AND TEAMS

1.4.1 General

Only those competitors who comply with the following IBU regulations shall be eligible to take part in Biathlon events and competitions organized by an IBU Member Federation. In order to be eligible to participate in an IBU event, Biathletes and team staff must sign the IBU Declaration for Obligations and the Court of Arbitration Declaration and the Declaration to fight doping in sport, which shall signify agreement to abide by and follow all IBU rules and policies. These Declarations must be signed prior to starting in the first IBU competition in which a Biathlete or staff member takes part. In addition, a copy of the passport must be attached. Each signed Declaration will remain in effect until terminated by either party.

1.4.2 A competitor must comply with Rule 45 and the By-Law to Rule 45 of the IOC Charter.

1.4.3 Competitor's Responsibility

A competitor may participate in an IBU event or competition only with material, equipment, clothing and advertising that are in accordance with the IBU Material Catalogue. It is the competitor's responsibility to ensure that all rules regarding material and advertising are followed and that he undergoes material, equipment and clothing inspections before the start and after the finish. All female competitors participating in IBU competitions are requested to certify their gender by their national passport.

1.4.4 Qualification Criteria

To gain the right to participate at OWG, WCH and WC events, the competitor must have attained a competition time not more than 20% in the Sprint or in the Individual behind the average of the top three placings at EC events (including ECH) or a top-half placing at the JWCH (not including YWCH) during the current or the previous season. All members of Relay teams must also have met this individual qualification requirement.

The following standards must be met in a WC competition for competitors to remain qualified for the following WC season:

Class	Sprint	Individual
Men	20%	or 20%
Women	20%	or 25%

For participation at WC and WCH, this requirement must be reached 1 time during the current or previous season. For participation at OWG, this requirement must be reached 2 times in the current and/or in the last season before the event.

Upon a request of a NF, the EB shall be entitled to grant an exception from this rule, if need be in an individual case for reasons such as pregnancy, injury etc.

The NFs and the Athletes must qualify for participation in the OWG.

1.5 REGISTRATION AND ENTRY

1.5.1 Notice of Intent to Participate at IBU Events

There are two separate forms of notification which must be given: registration and entry.

1.5.1.1 Registration and Replacements

Registration is the early notification of intent to participate. Numbers of Biathletes and team staff members that may be registered for an event are detailed in the event-specific rules. Registration for events must be done as follows:

a. WCH and Y/JWCH

For the WCH and Y/JWCH, the estimated number of Biathletes and team staff (registration by number) must be received by the OC two months before the beginning (first official training) of the WCH or Y/JWCH. At least 14 days before the official arrival day of the WCH or Y/JWCH, a list of the names and gender of the intended participants (registration by name) must be received from each NF by the OC. Replacement of registered participants must be notified to the OC immediately when the change is made.

b. WC Events

For WC events, the estimated number of Biathletes and team staff (registration by number and preliminary accommodation reservation) must be received by the OC one month before the beginning of the WC. A list of the names and gender of the

intended participants (registration by name and final accommodation reservation) must be received by the OC at least 14 days before the official arrival day of the WC. Replacements and changes may be made to WC registrations but the OC must be notified immediately when the change is made.

c. OWG

Registration for the OWG must be in accordance with IOC instructions.

d. Other Events

Registration for all other IBU events shall be at least one month for registration by number and at least 14 days for registration by name.

- 1.5.1.2** By sending a registration, a NF confirms and tacitly guarantees that all members of the team are covered by accident and liability insurance and that the athletes of the team are medically fit to compete.

1.5.2 Entry

Entry is the notification of an Athlete or team being entered to start in a specific competition and must be submitted in writing at least two hours before the draw for the Individual, Sprint and Super Sprint Qualification competitions at WC events, and four hours for all other events. Entry for team participation in the Relay and Mixed Relay competition in all applicable events (not OWG, WCH or WC) must be made not later than four hours before the Team Captains Meeting for the competition or the draw, if one takes place. At OWG, WCH and WC, entry for team participation must be submitted by 12:00 hours on the day before the Relay competition. Names of Relay competitors in start order must be submitted by 1600 hrs on the same day. Entries for the Pursuit competition are not required as all competitors who qualify for the Pursuit in the qualifying competition are assumed to be entered. Names of qualified Athletes who will not start in the Pursuit competition shall be reported to the competition office as soon as possible and at least two hours before the start. Entries for the Mass Start competition are not required as qualification is based on current WC Total Score and at WCH on previous competitions. However, the NFs are required to submit an entry form confirming the competitors' participation by the indicated deadline. Names of qualified Athletes who will not start in the Mass

Start competition shall be reported to the competition office as soon as possible and at least two hours before the start. The number of competitors that may be entered for a competition are stated in the event rules. Entries for the Super Sprint (Qualification and Final) competition shall be based on an invitation from the OC. The OC, together with the IBU, will define the system of qualification. The OC must provide a current weather forecast 30 minutes before the entry deadline so that the teams will have the latest information for preparing entries.

1.5.3 Registration Procedures

Registration must be sent in writing, by post, fax, email or via the online registration system, to the address indicated in the invitation before the deadline. For all IBU events, registration must be made by the NF. For the OWG, IOC regulations apply.

1.5.4 Late Entries

- The TD may approve a late entry due to extraordinary circumstances before the draw.
- The Competition Jury may approve a late entry due to force majeure after the draw. The Competition Jury will direct in which position(s) the late competitor(s) will start. A separate draw may be used for this purpose.

1.5.5 Replacement of Entry – Force Majeure

If an entered competitor cannot start due to force majeure, another registered competitor may take his place, but not later than 30 minutes before the listed start time of the entered competitor for Individual and Sprint competitions. In Relay competitions, competitors may be replaced as follows: first leg – 30 minutes before simultaneous start; second – before simultaneous start; third – before the first hand-over; and, fourth – before the second handover. In the case of such a replacement, a valid reason preventing the start must be presented to the Competition Jury not later than 30 minutes before the listed start time in question or before the deadlines specified for the Relay.

1.6 DRAW AND ASSIGNMENT OF START NUMBERS

1.6.1 General

Competitors or teams will be randomly selected from the entries for the competition, by manual or computer draw, and will be assigned

their start numbers based on that draw unless other rules regulate that competition. A draw will also be used to resolve any tie situation which cannot be resolved using the specific rules for that issue.

1.6.1.1 The method of the draw must be approved by the TD.

1.6.2 Time of Draws

The draw for any competition must be held not earlier than 24 hours before and not later than 15 hours before the start of the competition. However, in events at which a draw is required for the Mass Start or Relay competitions, the draw for the Mass Start and Relay competitions may be held at the Team Captains Meeting for the competition which will precede the respective Mass Start or Relay competition in the event program. If the Competition Jury decides to repeat a competition or to postpone a competition, they will also decide whether a new draw must be made.

1.6.3 Place of Draws

Draws must be held during and at the place of the Team Captains Meetings, and must be visible to all Team Captains; however, the TD may approve for a draw to be held outside of the Team Captains Meeting, if it is necessary due to event circumstances. Such outside draws must be supervised by at least two Competition Jury members.

1.6.3.1 Normal Assignment of Competitors into Draw Groups

When submitting their entries, Team Captains must assign one competitor to each of the draw groups. If a team consists of fewer competitors than the number of draw groups, the team captain will decide in which groups he will place his competitors (one in each group chosen). If a team consists of more competitors than the number of draw groups, the extra competitors shall be added to the draw groups at the team captain's discretion, one to each group, repeating this procedure until all the team's competitors have been placed.

1.6.4 Normal Draw for Individual and Sprint Competitions

The starting order shall be decided by randomly drawing the names of competitors from the draw groups into which they have been assigned by their Team Captains and by randomly drawing the start number for each competitor. The draw will be held separately for each group in this sequence:

Group 1, Group 2, Group 3, Group 4.

If the draw in the Individual or Sprint competition has 60 or less competitors, the draw will be done in 3 groups. If there are 40 or less then the draw will be done in 2 groups following the same principle as for the 4 draw groups.

1.6.4.1 At OWG, WCH and WC, the first group is reserved only for the top 30 competitors of the current WC Total Score. However, the Team Captains of those competitors will have the right to enter them in any draw group.

1.6.4.2 Draw for Group Starts in Sprint and Individual Competitions

At international competitions other than the OWG, WCH, Y/JWCH and WC competitions, the start for the Sprint and Individual competitions may be individual or in groups. If the start is held in groups, the draw groups shall be divided into start groups. The number of competitors in the start groups shall depend on the conditions at the competition venue and on the total number of competitors. Otherwise the draw shall be the same as for single starts. For a group start, the numbers drawn shall determine the competitors' positions at the start.

1.6.4.3 Assignment of Start Numbers and Start Times in the Pursuit Competition

No draw shall be conducted for the Pursuit competition. Competitors shall be assigned start numbers and times based on the results of the qualifying competition, which may be the Individual, Sprint or Mass Start competition as stated in the invitation. Competitors in the Pursuit will start in the same order in which they finished the qualifying competition: the winner of the qualifying competition will start first with start number 1, the second place of the qualifying competition will start second with start number 2, and so on. The winner of the qualifying competition will have a start time of zero (0) which will be shown on the start list as the clock time for the start of the Pursuit competition. The remaining competitors in the Pursuit competition will have as their start time the actual time by which they were behind the winner in the Sprint or Mass Start competition or — in the Individual — one half of the time behind the winner, expressed in time behind to the nearest full second. Start lists shall be produced based on the foregoing and must show the start lane assigned to each competitor. If there is a tie for place 60

in the qualifying competition, both of the tied competitors shall be allowed to start in the Pursuit. In Y/JWCH, CCH and CC Pursuit competitions, all competitors whose start times are more than five minutes after the start time of the leader will be started simultaneously at five minutes after the first start, but their actual competition times will show their times calculated from their actual start times from the qualifying competition.

1.6.4.4 Assignment of Start Numbers and Start Positions – Mass Start Competition

A provisional start list shall be made within two hours after the last qualifying competition. The start list will be finalized two hours before the start, by which time Team Captains must have confirmed their starters. Start numbers at WCH and WC events shall be assigned according to the applicable event rules. At all other events, if no appropriate ranking list is in force, a single random draw shall be used to assign the start numbers for all competitors, who shall not number more than the number of targets available. The start number shall designate the start position for each competitor at that competition.

1.6.5 Assignment of Start Numbers for Relay Competitions

1.6.5.1 Method of Assigning Relay Start Numbers

At OWG, WCH and WC events, no draw will be made for the Relay, and start numbers will be assigned based on the current standings in the WC Relay Score – with the top ranking team receiving number 1, the second number 2, and so on. If a team or number is missing, all teams below it will move upward in number. In the first WC of the season, the final standing of the previous year's Relay Score will be used to set the start numbers. At Y/JWCH and CCH, the previous year's Y/JWCH or CCH Relay results ranking will be used to set the start numbers in the same manner as above. For all unranked NFs, a single random draw will be used. For CC events, a single random draw will be used. The assigned Relay start number shall also be each team's start position for the simultaneous start and the shooting lane number on the range for the first bout of shooting only.

1.6.5.2 Placement of Competitors in Relay Start Positions

Start positions will be numbered from left to right, facing the

direction of the start. Number 1 will be the left position and the highest number of the front row will be the right position. The lowest number in the second row will be placed behind number 1 and the next consecutive number behind number 2, and so on.

1.6.5.3 Extra Relay Teams

Extra Relay teams shall not be permitted at OWG, WCH, Y/JWCH or WC competitions. At other events, extra Relay teams shall be permitted; however, they must start in rows behind the official teams and will not be awarded official prizes. Extra teams may consist of members from more than one NF.

1.6.5.4 Mixed Relay Teams – World Cup

No draw will be made for the Mixed Relay and start numbers will be assigned based on the sum of the NF's current Nations Cup Score for Men and Women – with the top ranking NF receiving number 1 and 2, the second number 3 and 4, and so on until the number 10. Then the next ranked NFs will receive numbers 11 and higher. If a team or number is missing, all teams below it will move upward in number correspondingly. The assigned Relay start number shall be each team's start position for the simultaneous start and the shooting lane number on the range for the first bout of shooting only.

1.7 TEAM CAPTAINS MEETINGS

1.7.1 General

At each Biathlon event, meetings must be held for the Team Captains to elect the Juries, conduct draws and to pass on information about the event and the competitions. The first meeting must be held at the latest on the day before the first day of Official Training in order to elect the Jury of Appeal and the Competition Jury. In regard to further meetings at the event, the dates and times will be dictated by the time required to conduct the draws. The Competition Chief shall chair the meetings.

1.7.2 Attendance at Team Captains Meetings

The following persons shall, if at all possible, attend the Team Captains Meetings:

- the official IBU EB representative;
- the TD(s) and IRs;
- Competition and Appeal Jury members;

- at least one representative from each participating team;
- the Competition Chief;
- the Chiefs of Range, Course, Timing and Results, Stadium, Logistics, and the Competition Secretary or their representatives;
- the necessary meeting support staff and interpreters, if required.

1.7.3 **Team Captains Meeting Agenda**

The agenda for a Team Captains Meeting must include the following items, as appropriate:

- Call to order;
- Roll call of nations (or teams);
- Election of the Jury of Appeal and Competition Juries (first meeting)
- Draw(s);
- Technical briefing for the next competition(s);
- TD's comments;
- Weather forecast;
- Miscellaneous;
- Adjournment.

1.7.4 **Start lists and start numbers for the Individual and Sprint Competitions**

should be issued to the teams at the end of the meeting.

1.8 **PROHIBITIONS AND SANCTIONS FOR NON-COMPETING PERSONS**

1.8.1 **General**

Unfair assistance or assistance not allowed by these Rules to competitors during a competition is prohibited.

1.8.2 **Specific Prohibitions**

1.8.2.1 **On the Shooting Range**

It is forbidden for any person to give competitors any acoustic or visual information or advice, or to pass on any information to competitors by way of radio or any other communication method on the range including 10 m to the left and right of the range. The forbidden area at the shooting range will be marked by clearly visible markings, including 10 m from the left and right shooting lanes. It is forbidden to pass any information from the shooting butts to the coaches and/or competitors during zeroing and/or the competition. These prohibitions shall not apply to the general expressions of applause or disappointment by the spectators.

1.8.2.2 **On the Course**

Pacing – running or skiing in front, beside or behind competitors – is forbidden. It is permitted to run without skis up to 50 m beside competitors to give competition information or to offer beverages. It is forbidden to touch competitors in such a way as to assist their propulsion or to obstruct other competitors. Assistance to competitors to change the glide performance of their skis is prohibited during the competition. In the area 100 m before and to 100 m after the range, in the handover zone and in the last 100 m before the finish, running beside competitors is forbidden.

1.8.3 **Sanctions**

Spectators and other persons must be clearly informed of these rules by the official announcer before the beginning of the competition and warned that a violation of these rules, or any behavior that disrupts the event may lead to spectators and other persons being removed from the venue by the Organizing Committee.

1.9 **Awards**

IBU medals will only be given for competitions where three or more competitors or Relay Teams are competing.

2. **ORGANIZATIONS AND APPOINTMENTS**

2.1 **GENERAL**

The following organizations and persons shall be established, elected or appointed for the preparation, conduct and control of Biathlon events and competitions:

- Organizing Committee;
- Jury of Appeal;
- Competition Juries for Men and Women;
- TD(s) and IRs;
- IBU EB Representative (if applicable);
- IBU Medical Delegate (if applicable);
- IBU Race Director (if applicable).

2.2 **THE ORGANIZING COMMITTEE**

The right to host an event or competition shall be awarded to a NF as host of the event. The NF must establish an Organizing Committee to prepare and conduct the event or competition by these Rules and the applicable event rules, and it shall follow the directives

provided in the Organizers' Guide about all aspects of hosting an event. In order to be eligible to host an IBU event or competition, a NF must present a site holding a valid IBU site license for the facility for the appropriate event.

2.2.1 Information Bulletins and Invitations

The OC of an IBU event must send the information bulletins and/or the invitation for the event to all IBU NFs as stipulated in the event rules, on the required dates by post, fax or email. The contents of invitations and bulletins are provided in the Organizers' Guide.

2.3 THE COMPETITION JURY

2.3.1 General

A Competition Jury shall be established for all Biathlon events to act as the authority on all matters related to the event that are not specifically designated to be under the jurisdiction of other IBU Organs. The Competition Jury shall be established and operate in accordance with these Rules. Generally, a separate Competition Jury shall be established for Men's and Women's competitions. However, at certain events, in particular at Y/JWCH, CCH, CC and Mixed Relay WCHs, the TD may also form a joint Competition Jury (e.g. Youth Men and Youth Women; Men/Youth and Junior, Women/Youth and Junior). The Competition Jury will make decisions about the event, competitions and related arrangements and conditions to ensure fairness and correct procedures. The Competition Jury shall impose penalties for rule violations reported by the TDs, IRs, competition officials and Competition Jury members, and penalties and disciplinary measures on its own part. Additionally, the Competition Jury shall award time adjustments and is to rule on competition situations not stipulated in these Rules or other authoritative IBU publications. The Competition Jury shall also review and decide on all protests submitted to it. The procedures of the Competition Jury shall be governed by the IBU Disciplinary Rules.

2.3.1.1 Time of Election

The Competition Juries to be established for an event must be elected at the latest on the day before the first Official Training. The Competition Juries shall remain competent throughout the event; however, changes of elected members may be made by election for pressing reasons.

2.3.1.2 Chair

The chairperson of the Competition Jury shall be the TD.

2.3.2 Competition Jury Composition

At all IBU events the Competition Jury shall consist of five members as follows:

- the IBU TD as chairperson;
- the Assistant IBU TD at OWG;
- the Competition Chief;
- three (or two at OWG) team officials elected by the Team Captains.

2.3.2.1 Only one person from a NF may be a member of a Competition Jury at the OWG, WCH, Y/JWCH, WC, ECH and EC competitions.

2.3.2.2 At other international competitions, the composition of the Competition Jury shall be agreed upon by the OC and the Team Captains of the participating Federations or regional organizations.

2.3.3 Election of Competition Jury Members

Election of the Competition Juries shall be conducted by the TD during the Team Captains' meeting. Nominations of candidates may be made by the TD or Team Captains. If there are the same number of candidates as open Competition Jury positions, no vote will be necessary and the candidates shall become Competition Jury members by acclamation. If there are more candidates than open Competition Jury positions, a vote must be taken from the Team Captains. Only one vote per NF will be allowed. A simple majority will elect a Competition Jury member. If no simple majority is obtained by any candidate, the person with the least votes will be removed as a candidate and the vote will be repeated for the remaining candidates until the Competition Jury members have been elected.

2.3.4 Competition Jury Meetings and Decisions

The Competition Jury must be able to assemble within a minimum of time whenever a meeting is required, as directed by the Competition Jury Chairperson, and must remain readily available for Competition Jury duties for 15 minutes after the Provisional Results have been published. Specific meeting times are detailed in Annex B to these rules. Decisions of the Competition Jury shall normally be made with all members present. However, in exceptional cases the Competition Jury shall be competent to pass a resolution if at least three members are present. The Competition Jury Chair shall only vote in

case of a tie vote. Decisions shall be made by each member voting on the issue and a simple majority shall decide.

2.3.5 Tasks of the Competition Jury

A detailed list of tasks of the Competition Jury is given in Annex B to these Rules.

2.3.6 Appeals Against Competition Jury Decisions

An appeal may be made against penalties and disciplinary measures imposed by the Competition Jury. The appeal must be made to the Jury of Appeal established for the event concerned, and be put forward in accordance with the IBU Disciplinary Rules.

2.4 TECHNICAL DELEGATES

2.4.1 General Regulations

TDs shall be appointed by the IBU TC and will officially represent the IBU. TDs shall be responsible for ensuring that events are prepared and conducted in accordance with IBU rules. Additionally, TDs will act as consultants and advisors to the OC. OCs must follow instructions issued by TDs in accordance with these Rules.

2.4.2 Appointment of TDs

TDs shall be appointed by the IBU TC from among its members or from the TD group at least three years prior to OWG, two years prior to WCH and in the season before for all other IBU events, and may not be from the host NF. Two TDs shall be appointed for the OWG, one as an assistant TD. For all other events, one TD shall be appointed.

2.4.2.1 The TD shall be Chairperson of the Competition Jury or Juries for the event for which he has been appointed. At OWG, the assistant TD shall be a member of both the Men's and Women's Competition Juries.

2.4.2.2 If the appointed official representative of the IBU from the EB is not present at a WCH, Y/JWCH, WC or ECH, another member of the EB, the TD or the RD shall perform that function.

2.4.2.3 A TD's function shall be valid only for the event for which he has been appointed.

2.4.3 Contact with OCs and Site Visits

Immediately after being appointed, the TD must establish contact with the OC. TDs shall conduct the necessary inspections of the event site and meetings with the OC. TD inspections and meeting visits to event sites must be reported to the IBU TC and IBU Headquarters for prior approval.

2.4.4 Tasks and Duties of TDs

The TD must arrive at the event site in sufficient time before the event and must perform all the necessary functions required by these Rules and the circumstances at the venue before, during and after the event. The TD shall be responsible for directing the IRs during the event. Detailed tasks and duties of TDs are given in Annex B to these Rules.

2.4.5 TD Expenses

OCs of IBU events and competitions are responsible for paying the TDs' travel, accommodation and meal expenses for the period of the TDs' duty, and daily allowance as stipulated by the IBU regulations in force at the time.

2.5 INTERNATIONAL REFEREES

2.5.1 General Regulations

IRs are persons who are appointed by the IBU TC to officiate at IBU events. They are responsible for the correct performance of duties and tasks related to their area of responsibility, in cooperation with the Competition Committee. In addition, IRs shall be required to direct, advise and assist other competition officials in their duties, and to intervene to prevent mistakes from being made. The IRs at an event shall be subordinate to the TD, report to him on the performance of their duties and must follow his directions.

2.5.2 Appointment of IRs

IRs appointed by the TC for the OWG, WCH, Y/JWCH, WC, and ECH must hold a valid TD license. IRs for other events may be appointed by the respective NF or OC and must hold a valid IR license. At EC events, one of them must hold a valid TD license. In order to serve as an IR in another nation, the person must have held a valid IR license for at least four years; however, exceptions may be permitted by the TC. At OWG, WCH and Y/JWCH, all appointed IRs must be from outside the host nation. For WC and ECH events, the IRs

Range, Start/Finish and Material Inspection must be from outside the host nation and must be members of the TD group. At CCH and CC all IRs may be from the host nation.

2.5.2.1 At OWG, WCH and the first WC event of the season, the IR for Material Inspection should be a member of the TC Material Sub-Committee.

2.5.3 IR Functions at Competitions

The functional areas where IRs will be employed at competitions will be:

- start/finish;
- shooting range;
- course;
- material inspection.

2.5.4 Numbers of IRs for Events

The following numbers of IRs shall be appointed for events:

- a. OWG 8
- b. WCH 4
- c. Y/JWCH 4
- d. WC 4
- e. CCH 4
- f. CC 4

2.5.5 IR Tasks and Duties

Detailed tasks and duties of IRs are given in Annex B to these Rules.

2.5.6 IR Expenses

OCs of events and competitions shall be responsible for paying the IRs' travel, accommodation and meal expenses and daily allowance as stipulated by the IBU regulations in force at the time for the period of the IRs' employment.

3. COMPETITION VENUES AND FACILITIES

3.1 GENERAL

The competition venue is the site on which Biathlon competitions and training are conducted, and consists of the stadium area and the course. Located in the stadium area are the start/finish areas, shooting range, penalty loop, Relay hand-over zone, ski test area, team wax huts, team lounge, athlete changing area, spectator areas

and parking spaces, as well as the buildings and offices necessary for the OC. The venue must be technically suitable, according to these Rules, to allow all the types of Biathlon competitions to be held, and must offer the best possible viewing of the competitions to spectators, and fulfill all the requirements of TV coverage. Venues that are candidates for hosting the WCH and WC must have an IBU A license, and for Y/JWCH, ECH and EC events must have an IBU B license. Venues for OWG must acquire an IBU A license.

3.1.1 General Requirements

The start and finish areas, shooting range, penalty loop and Relay hand-over zone shall be located on level ground and close together, so as to provide good viewing of competition activities for the majority of the spectators. These areas and critical parts of the course must be fenced off in order to prevent competitors from being impeded or going astray, and to prevent access by unauthorized persons. However, the height and extent of the fencing must be minimized as much as possible to avoid interference with TV coverage. There must be sufficient space for competitors and competition officials to conduct their required activities and adequate room for team support staff, press, photographers and spectators, and enough space for TV camera crews and their broadcasting facilities without the broadcasting interfering with the competition. Diagrams of examples of facility lay-outs are given in the Organizers' Guide.

3.1.1.1 Maximum Distance

The competition venue must be no more than 30 km or 30 minutes travel from the teams' living accommodations, unless otherwise approved by the IBU EB.

3.1.1.2 Competition Office

A Competition Office or sub-office must be located in or near the stadium area. The office shall be open during regular hours during the entire event, beginning on the arrival day, and will be the official interface between teams and the Organizing Committee. Teams must be able to submit entries for competitions at the office and information about the event and competitions must be available in the office. A mailbox for each participating team must be provided in the office or close to it.

3.1.1.3 Electronic Information Board

At OWG, WCH, Y/JWCH and WC there must be an electronic information board with at least eight lines, in the stadium area, in a location as approved in the licensing process or by the TD and RD.

3.1.2. Artificial Lighting

IBU competitions may be held under artificial lighting when approved by the EB or TC as part of a given program. Under exceptional circumstances, the Competition Jury may authorize that a competition be held under artificial lights. In any case, the lighting must meet the following standards:

- Lighting conditions must be the same for all competitors;
- There must not be any danger for anyone involved caused by the lighting;
- If TV is involved, the light conditions must satisfy TV requirements.

3.2 START AND WARM-UP AREAS**3.2.1 General**

The start area for all competitions must be level with the snow well packed and smoothly groomed, and should be visible to spectators. The start line shall be placed at right angles to the skiing direction and will be marked with a red line sunken into the snow. The area must be well fenced-off and must be suitable to cope with the traffic flow of competitors, team support staff and officials without problems. There must be a warm-up area immediately adjacent to the start zone for competitors to perform their final, pre-competition warm-up, with enough room to store warm-up clothing, and space for an adequate number of rifle racks, as directed by the TD.

3.2.2 Individual and Sprint Competition Start Areas

The start area for Individual and Sprint competitions must be approximately 8 - 10 m long and a minimum of 2 m wide and must be separated from the warm-up area by a fence with an opening to allow controlled access to the area.

3.2.3 Pursuit Competition Start Area

The start area for the Pursuit Competition must have a minimum of three start lanes, and the actual number of start lanes will be determined by the number of simultaneous starts in the start list – if there are four starts in the same second, then there must be four start lanes, etc. The start lanes must be 1.5 – 2 m wide and

sufficiently long to hold the required number of competitors. A common start line must cross the end of the start lanes. The lanes must be immediately parallel to each other and must be clearly separated. There must be a separate passage or lane which allows access across the start line in the case of late starts. This lane must be supervised by a start official with a stopwatch synchronized to the competition time.

3.2.3.1 Pursuit Start Boards

Separate boards, showing the start numbers and start times for each lane in large print easily readable by competitors and officials, must be positioned in front of the applicable start lanes and at the start line.

3.2.4 Relay, Group and Mass Start Competition Start Area

The start area must be laid out in such a way that all the competitors will be required to ski the same distance until they reach the common course. A minimum of ten straight, parallel sets of tracks, with a minimum of 1.2 m between each set of tracks (measured from center to center), must be set for a minimum of 35 m from the start line. The number of start tracks will depend on the space available and the number of Relay teams entered, with the objective of having the fewest possible start rows. If there is more than one start row, the distance between rows must be 3.5 m. The end of the parallel tracks must be clearly marked. After the first parallel-tracked section there must be a further 50 m of straight, level and smoothly groomed, trackless, gradually converging area that leads to the competition course.

3.2.4.1 Start Position Boards – Relay, Group and Mass Start competition

The start positions must be marked with numbers. There must be the same number of boards as the number of starters in the competition. The size of the board must be 20 x 20 cm. The number boards are to be placed on the left of each position and the number must be readable from the front and the rear. The numbers on the boards must be at least 10 cm high and must be highly visible to the competitors and TV.

3.2.5 Course Information Boards

There must be a board at the entrance to the start area on which the course map shows the color sequence for the competition.

3.2.6 Start Clocks

At the start area for Individual and Sprint competitions, there must be a start clock placed so that it is easily readable from the start line. The display of the clock and the sound signal must be synchronized. For the Pursuit competitions, there must be a start clock for each start lane. As well, in or near the start area there must be a clock displaying the correct time of day, which must be easily visible to competitors in the area.

3.2.7 Start Equipment/Material Inspection

The equipment/material inspection prior to the start must be located in close proximity to the start area. Its placement and design must facilitate the smooth, orderly and timely flow of competitors through to the start. The inspection station must have tables and the required equipment and materials to perform the checks.

3.3 COURSE AND ASSOCIATED SECTIONS**3.3.1 General**

The course is the network of ski trails to be used for the competition. It shall consist of continuously changing flats, climbs and downhill sections. Extremely long and difficult climbs, dangerous descents and monotonous flats are not permitted. Changes in direction of the course must not occur so frequently that a competitor's ski rhythm is seriously disturbed. Detailed course specifications are given under 1.3.7 in Table 1.

3.3.1.1. TV Zones

Zones for TV coverage of the competitions will be established on the course, in consultation with the RD, TD and TV advisor responsible for the event. The primary purpose of the zones shall be to ensure the best possible coverage of the competition and in particular to prevent obstruction of the TV image by non-competing persons.

3.3.2 Altitude, Width and Length

The maximum altitude of any part of the course may not be higher than 1800 m above sea level, unless an exception is specifically authorized by the IBU EB in necessary circumstances. For all IBU events, the course must have a minimum width of 6 m of groomed snow surface. If required in places like difficult climbs, the trail must be even wider. If narrower sections such as bridges or mountain passes are unavoidable, the narrow parts may not be less than 4 m

wide or longer than 50 m. The actual length of the course may not differ by more than 5 % from the length specified for the competition.

3.3.3 Setting of Tracks

If required, tracks will also be laid in downhill sections as directed by the TD. Tracks must not be set in such a way or in places where they may endanger or hinder competitors. The width and depth of tracks must be set so that all regular types of boots and bindings can be used without side friction.

3.3.4 Safety

The course must be prepared so that a competitor may ski it at full speed without undue risk of an accident.

3.3.5 Grooming

The course must be as level as possible, solidly packed and smoothly groomed. Downhill turns must be banked as necessary. All types of hindrances and obstacles must be cleared from the course, such as stumps, branches, stones and soil. Overhanging or protruding branches must be trimmed so that they do not obstruct or endanger competitors.

3.3.6 Marking

The course must be so clearly marked and defined so that at no time a competitor is in doubt how to follow the course. This applies especially to descents and other critical points. Clear markings must be placed at such points. At 100 m from the finish line there must be a sign board indicating "Finish - 100 m".

3.3.6.1 Course Sequence Colors

The course must be uniformly marked on the most visible side in the ski direction by colored sign boards. The 1.5 km course must be marked orange, the 2 km course must be marked red, the 2.5 km course green, the 3 km course yellow, the 3.3 km course blue and the 4 km course brown. Junctions must be clearly marked with course colors.

3.3.7 Fencing

All trails that will not be used in the competition must be closed. Trails close to each other must be separated by fences or V-boards so that competitors cannot go on the wrong trail.

3.3.8 Forerunners

Immediately before the start of the competition the entire course must be skied before the first competitor's start by the course crew. While on the course, they will clear it and correct the markings, if required. The TD and IR will decide whether to use forerunners or not.

3.3.9 Course Specifications for Competitions

Table 1 under 1.3.8 details the required technical specifications for courses for each type of competition.

3.3.10 Relay Hand-over Zone

In Relay competitions there must be a well-marked hand-over zone, 30 m long and 8 m wide, at the end of a straight trail section placed in such a way that incoming competitors will arrive at a controlled speed. The last 50 m of the trail before the zone must be at least 8 m wide. The hand-over zone must begin at the timing line or at least close to it. The beginning and end of the zone must be marked with a red line and with a sign at the beginning: "Hand-over zone". The zone must be fenced along both sides, with one access gate for controlled entry by starting competitors.

3.3.10.1 The last 50 m of the course before the hand-over zone must be straight. The hand-over zone may only be entered by the incoming and outgoing competitors and by the officials responsible for control of the hand-over zone. At 100 m before the hand-over zone there must be a sign board indicating "100 m".

3.3.11 The Penalty Loop

For the Sprint, Pursuit, Mass Start and Relay competitions, a penalty loop must be set up immediately after the shooting range – no further than 60 m skiing distance from the right edge of the range to the entrance of the penalty loop. The loop should be an oval trail which is 5 m wide and 150 m (plus or minus 5 m) long, measured along the inside perimeter of the loop. The penalty loop must be marked off with V-boards, set up so close together that competitors have no chance of mistaking the entrance/exit.

3.3.11.1 The penalty loop must be located in a level area in such a way that no additional distance between the course and the penalty loop has to be skied by the competitors when they have to enter the penalty loop.

3.3.12 Ski Test Area

At all IBU events, a ski glide test area must be set up on slightly sloping terrain in or near the stadium area, large enough to accommodate all participating teams, including sufficient space to accommodate the traffic flow ascending the slope. The glide test downhill slope should have a gradient of 8 to 12° and be a minimum of 30 m long. The test area must be prepared and groomed in the same way as the competition trails. In the ski test area there must be an information board on which the temperature of the air and the snow at the highest and lowest points of the course profile shall be shown, and updated three hours prior to the first start and thereafter every 30 minutes until the last competitor has started.

3.3.13 Warm-up Course

For all IBU events there must be a separate course, in close proximity to the stadium and with easy access from the team huts, on which competitors can warm up. The course should be approximately 600 m long and must be prepared the same as the competition course but cannot be a part of the competition course. This warm-up course should also be in place for all other events.

3.4 SHOOTING RANGE**3.4.1 General**

The shooting range is where all shooting takes place during a Biathlon competition. It must be located in the central area of the stadium and both the targets and the shooting ramp must be visible to the majority of spectators. The range must be flat and level and must be surrounded by adequate safety berms on the sides and behind the targets in accordance with the applicable national safety rules. The shooting range must be set up and placed with strict regard for safety in relation to the trails, stadium and the surrounding area. The shooting direction should be generally northward with consideration for the light conditions during competitions. Safety baffles which obstruct visibility of the competition to spectators or TV should be avoided if at all possible.

3.4.1.1 The shooting range must conform with all local laws.

3.4.2 Specifications and Configurations

3.4.2.1 Shooting Distance

The distance between the front edge of the shooting ramp (firing-line) and the line of targets must be 50 m +/- 1 m.

3.4.2.2 Prone and Standing

Looking in the shooting direction, the right half of the range shall be for shooting in the prone position and the left half for shooting in the standing position. The division must be clearly indicated to the competitors by sign boards. An exception to the right and left configuration is to be made during Pursuit, Mass Start and Relay competitions, when competitors fire from all lanes in both prone and standing positions.

3.4.2.3 Entrance and Exit

During both training and competition, competitors must enter the range from the left and exit on the right side.

3.4.2.4 Levels

The surface of the shooting ramp and the surface on which the targets are situated must be as near the same level as possible. The shooting ramp and the surface on which the targets are placed must be at a higher level than the ground between them by at least 30 cm, and more if required by local snow conditions.

3.4.2.5 Space Configurations

At the rear of the range there must be a fenced off area of 10 to 12 m width (shooting ramp), measured back from the front edge of the firing line, and extending along the entire back of the range. The area is to be reserved for competitors, officials and members of the Juries. However, if authorized by the TD, other persons such as TV camera crews may be allowed in this area. Directly behind that area there must be a second fenced area of at least 2 m width reserved for three team staff members per team. This area must be configured so that the team staff members have good visibility of the targets and the shooting ramp area. Behind the coaches area there must be an area 1.5 m wide, extending the width of the range, reserved primarily for the media.

3.4.3 The Shooting Ramp

The shooting ramp is the area at the rear of the range where the competitors lie or stand to fire. The ramp must be totally covered with

snow, solidly packed, even, smoothly groomed and not icy, and the entire area used by competitors during the competition must be level.

3.4.3.1 Shooting Lanes

The shooting ramp is divided into shooting lanes from which one competitor at a time will shoot. Every shooting lane must be at least 2.7 m but not more than 3 m wide (the ideal is 2.75 m). The width of the lanes must be marked on both sides on the shooting ramp from its front edge for a distance of 1.5 m to the rear with a red-colored board sunken into the snow so that it is 2 cm below the snow surface. Both sides of each lane must be marked from the ramp to the targets with T-posts, in alternating colors matching the background color of the target numbers, which clearly define the lanes but do not interfere with shooting. There must be a distance of 3 m between the outer edge of the left and right lanes and the start of the safety berms they adjoin. This distance must be maintained from the ramp to the targets.

3.4.3.2 Shooting Mats

For shooting in both the prone and standing positions, mats must be placed at the front part of each shooting lane on the shooting ramp. For all IBU events, the mats must be 200 cm x 150 cm and 1 to 2 cm thick, and must be made of synthetic or natural fibers with a non-slip surface.

3.4.4 Targets

There are two main kinds of targets used for Biathlon - metal and paper. Only metal targets shall be used for competition and only paper targets shall be used for rifle zeroing. Both paper and metal targets may be used for training. Only targets which are in conformity with the IBU Material Catalogue (Annex A) may be used for IBU competitions. A shooting range for OWG, WCH, Y/JWCH, WC, ECH and EC competitions must have at least 30 shooting lanes and targets. The targets used for OWG, WCH and WC must have a remote reset capability (without rope).

3.4.4.1 The same type of targets must be used for all competitors in one competition.

3.4.4.2 Target Maintenance

Targets must be maintained, set and adjusted according to the manufacturer's instructions.

3.4.4.3 Target Placement

The targets must be set up in a level straight line, parallel to the front edge of the shooting ramp. They must be level in all directions. The targets must be placed so that the target is in the middle of the width of the lane. The targets must not deviate sideways more than 1 degree from the right angle lines of their shooting lanes. The target center must be 80 to 100 cm higher than the surface of the shooting ramp.

3.4.4.4 Target Background

The background behind the targets must be white from the bottom of the target to 1 m above the upper edge of the target.

3.4.5 Numbering and Markings

The shooting lanes and the corresponding targets must each have the same number, easily visible, and beginning from the right with number 1. At OWG, WCH, Y/JWCH and WC competitions the shooting lanes must be numbered on the left and right side at the front edge of the shooting ramp. The numbers at the shooting ramp must be placed so that they do not obstruct TV coverage of the shooting competitors. They must be 20 cm high and the lines of the numbers 3 cm in width, mounted on a support post 1 cm thick and 40 cm high — measured from the snow surface to the bottom of the number plate. The overall size of the number sign is specified in the IBU Rules for Advertising. The size of the target numbers shall be 40 cm high with a line width of 4 cm and they must be mounted immediately above the targets. Both the target and firing point number signs must be in alternating colors — black on yellow and yellow on black — starting at number 1 with black on yellow and matching the t-post lane markers.

3.4.5.1 Entrance and Exit Boundaries

At the entrance and exit of the range, 10 m outward from the left and right hand shooting lanes, there must be a clear marking. These markings shall indicate the outer edges of the information prohibition zone of the range.

3.4.6 Wind Flags

At competitions and official training, wind flags must be installed at the side of every third shooting lane beginning at the right side of lane 1, at 5 m from the shooting ramp and 20 m from the target.

The flags must be placed so that the top edge of the flag is at the same level as the bottom edge of the targets and can not obstruct a direct line of sight to the targets.

3.4.7 Relay Cups

At each firing point there must be a cup for spare rounds placed 1 m above the ground. The cups must have rounded bottoms and must facilitate the easy picking-up of the spare rounds.

3.4.8 Rifle Racks

Suitably placed on the range in front of the team staff area, there must be racks for two reserve rifles for each participating team during competitions and an adequate number of these racks for during training and zeroing. The racks must be clearly marked with the names of the participating nations or teams. The racks may be used by teams during competition, training and zeroing. Outside the range there must be an adequate number of racks for training.

3.4.9 Video Cameras on Range

For OWG, WCH, Y/JWCH and WC competitions, video cameras must be installed on the shooting range in sufficient number so that the placement and number of cameras totally covers and records all actions of all competitors on the range.

3.5 FINISH AREA**3.5.1 General**

The finish zone begins on the competition trail at the finish line and ends at the finish equipment/material and clothing inspection point and must be at least 30 m long and 8 m wide without obstruction. The last 50 m before the finish line must be straight and 8 m wide. Only officials, finishing competitors and specially authorized TV personnel under supervision of the IR Start/Finish are permitted in the finish zone.

3.5.1.1 The finish line must be marked by a sunken red line in the snow at a right angle to the incoming trail and clearly visible to the competitors and broadcasters' cameras.

3.5.2 Finish Equipment/Material Inspection

The finish equipment/material inspection must be located so that finishing competitors flow into it automatically and can pass through it under supervision. This is particularly important for Relay

competitions so that finished competitors do not obstruct the outgoing trail from the hand-over zone. The finish zone fencing and placement must be set up so that competitors are automatically led into, and have no way of evading, the finish equipment/material inspection.

3.5.3 **Media Area**

Adjacent to the finish zone, a fenced-off area (Mixed Zone) has to be established for TV company representatives, journalists and photographers to have close contact with the competitors for interviews and pictures after they finish.

3.5.4 **Refreshment Point**

There must be a refreshment point after the finish zone, its location to be agreed with the TD, to serve drinks, and to provide paper tissues and similar necessary services to competitors after they finish. Any beverages or foodstuffs provided there must be protected against any introduction of unauthorized substances.

3.5.5 **Clothing Change Shelter**

Adjacent to the finish zone, there must be a shelter providing privacy where competitors can change their clothing. The size of this shelter shall be approximately 2 x 3 m.

3.5.6 **Finish Exit Zone**

After the finish zone, there must be an area where the competitors can meet their team staff, service firms and retrieve their clothing and materials/equipment.

3.6 **TEAM WAX CABINS**

In or very near the stadium area, there must be a sufficient number of shelters, permanent buildings or good quality temporary structures in which teams may store materials/equipment, wax skis and keep warm. The cabins must be provided with ventilation — adequate for extracting wax fumes — lights and electric power outlets, and must be warmed to at least 20 degrees Celsius. Each team should have its own cabin but combining of more than one team per cabin shall be allowed however, if work-space and security regulations permit. The cabins should be equipped with locking doors and teams are to be issued with corresponding keys. If the entrances cannot be locked, the OC must provide security for the cabins. Parking space for teams must be provided within a reasonable distance of the

cabins. A loudspeaker of the public address system should be placed near the cabins.

3.7 **COMPETITOR WAITING ROOMS**

Rooms must be provided near the wax cabins as waiting area for the competitors. This can be a part of the stadium building, a separate warming shelter or a tent.

4. **COMPETITION EQUIPMENT AND CLOTHING FOR EVENTS**

4.1 **GENERAL RULES**

The term competition materials/equipment and clothing includes all of the materials, equipment, competition gear and clothing which the competitor uses during an event, including advertising. The definitions and specifications of competition materials/equipment and clothing, and advertising, are regulated by the IBU Material Catalogue (Annex A) and the IBU Rules for Advertising.

4.2 **INSPECTIONS OF EQUIPMENT/MATERIAL AND CLOTHING**

4.2.1 **General**

Competitors' materials/equipment and clothing shall be inspected before the start and after the finish of a competition. Additionally, a preliminary materials/equipment and clothing check is to be provided well in advance of a competition to ensure that no problems occur. No equipment, material or clothing may be used at an IBU event unless it has been approved by the IBU.

4.2.2 **Start Materials/Equipment and Clothing Inspection**

Competitors shall report at the start materials/equipment and clothing inspection area not later than 15 minutes prior to their scheduled time of start to have their skis and rifle checked and marked, and their clothing inspected. Competitors whose materials, equipment or clothing do not conform with IBU regulations will not be authorized to pass through the start materials/equipment and clothing inspection until the discrepancies have been corrected. Equipment, rifles, materials and clothing which have been inspected and marked at start equipment inspection must not be modified in any way prohibited by these Rules or the IBU Material Catalogue.

Team reserve rifles — maximum two per team — are to be brought to the materials/equipment and clothing checkpoint for inspection and marking, and then must be taken directly to the range and deposited in the reserve rifle racks before the first start. The range staff will not permit the deposit of rifles after this time. To facilitate the inspection of the reserve rifles, the materials/equipment and clothing checkpoint must be opened at least 15 minutes before the start of zeroing and the competitors shall have the right to have their rifles checked from that time onwards. The early opening of the start equipment inspection shall be permitted and encouraged at all competitions in order to avoid time difficulties.

4.2.2.1 Specific Checks at Start Equipment Inspection

The following checks are to be made:

- a. That the competitor is wearing his start number and thigh numbers;
- b. The rifle shall then be safety-checked to confirm it does not contain a live cartridge in the chamber or in its inserted magazine;
- c. The weight, trigger resistance, dimensions and shape of the rifle, and the advertising on it shall be checked for correctness. The rifle shall be marked with a small sticker affixed to the top front end part of the forestock that must be clearly visible to officials at the start and finish, and the serial number shall be recorded on a check list so that the rifle can be verified at the finish in case the sticker falls off;
- d. Skis and poles shall be checked for correctness and the skis marked;
- e. Clothing and other materials/equipment shall be inspected for correctness, including advertising;
- f. Magazines may be spot checked to ensure they contain only five rounds that can be fired directly from the magazine.

4.2.2.2 Markings

Marking of equipment shall be done to prevent unauthorized change of equipment during the competition by using the competitor's start number. Both skis and the rifle shall be marked. In Individual, Sprint, Pursuit and Mass Start competitions, only one color shall be used to mark the skis. The marking shall be made with a colored marker pen or stamp, and shall be unique for that competition. In Relay

competitions, the skis must be marked according to the team start numbers and the colors or numbers of the start sequence within the team. The inspection sticker for the rifle must be placed on the top front end part of the forestock.

4.2.2.3 Delays before Start

Delays before starting times because of a competitor reporting late at the equipment inspection area, or corrections that have to be made to his clothing or equipment, shall be the responsibility of the competitor. The OC must provide sufficient staff to ensure prompt equipment inspections and thus prevent late starting times of competitors who have reported in time.

4.2.2.4 Final Check Before Start

Between one to two minutes prior to the start, a check shall be made of the competitor by the starter's assistant(s) in order to ensure the following:

- a. The competitor is wearing a start number and thigh numbers;
- b. The skis and rifle are properly marked;
- c. Advertising regulations are not being violated;
- d. By opening and closing the action of the rifle, that there is no round in the chamber or the inserted magazine;
- e. That the competitor has enough magazines;
- f. That the competitor is not in possession of any wireless communication device.

4.2.3 Finish Inspection

After arriving at the finish and — in Relay competitions — after the handover zone, a check shall be made to confirm the following:

- a. The rifle does not contain live ammunition in the chamber or the inserted magazine;
- b. Competitors have finished with at least one marked ski and their marked rifle, with the skis and poles in accordance with the Material Catalogue;
- c. The rifle trigger resistance is at least 0.5 kg (may be conducted as a spot check, if authorized by the TD);
- d. The advertising regulations were not violated.

4.2.4 Preliminary Examination of Materials/Equipment and Clothing

At OWG, WCH, Y/JWCH, WC, ECH and EC events, the TD, IR Material Inspection and RD shall conduct a preliminary inspection of

equipment to confirm that the materials, equipment and clothing to be used by teams are permitted by the rules. The check will normally be done at least two days before the first competition. The preliminary examination does not relieve competitors of the obligation to pass equipment inspection at the start and finish.

4.2.4.1 Attendance

The examination will be conducted by the responsible staff of the Organizing Committee. The IR Material Inspection must also be in attendance. The examination shall be voluntary but a team representative should attend if the use of items of clothing, materials or equipment should be questionable. At the OWG, the first WC and EC event of a season, it is mandatory that each competitor attend with his rifle and that at least one representative of each team attend the examination. Competitors or teams who are not present at the first WC or EC must make this inspection prior to their first start of the season.

5. TRAINING AND ZEROING

5.1 GENERAL

Competitors and team staff must be provided the opportunity and the facilities to prepare for the competitions. For that purpose the OC must set Official Training times, provide ski testing facilities, and offer the opportunity for competitors to zero rifles and warm-up prior to the competition.

5.1.1 Exceptions

In extraordinary circumstances, the Competition Jury may close the entire facility or limit training on the facility to certain parts or to specific times.

5.1.2 Rights for Training and Training Bibs

Competitors who have registered for an IBU event may use the course during the Official Training. Men and Women may not participate in Official Training and zeroing for the other gender, however, the TD shall have the authority to permit mixed training on competition days when this is in the best interest of the competitors and the OCs. The training bibs assigned by the IBU must be worn by all competitors during training, and by team staff and service firms personnel using the course at any time during the event.

5.1.3 Types of Training

Official Training is the period of time that the OC must provide for training on the facility. The facility must be prepared the same as for the competition. Unofficial Training is the time that the OC allows for training on the facility in addition to Official Training, when the facility does not have to be prepared as for the competition. OCs should allow as much time as is possible in the event program for Unofficial Training – if necessary, shooting lanes will be allocated for teams as for Official Training, as directed by the TD.

5.2 OFFICIAL TRAINING

5.2.1 General

At OWG, WCH, Y/JWCH, WC, CCH and CC events the competition facility must be open for inspection and Official Training at least once before the first competition. The facility must be prepared as for the competition and the training must be held at the same time of day as the competition itself. Each subsequent competition should also be preceded by Official Training unless it is not possible in the event program or due to other circumstances.

5.2.1.1 Skiing Training

The competition course for Official Training must be open at the times corresponding to the competition times, if possible, and must also be groomed, marked and fenced or barricaded as for the competition.

5.2.1.2 Shooting Training

The shooting on the day prior to the competition should be organized at times corresponding to those of the competition day. The shooting will begin at the same time as the zeroing time of the competition day, with only paper targets in use and on designated shooting lanes. After 30 minutes, metal and paper targets will be used and the choice of shooting lanes will be free, until the end of the training period. When the metal targets are opened for Mass Start and Pursuit Official Training, the odd-numbered shooting lanes will be set to Prone and the even-numbered lanes will be set to Standing.

5.3 RIFLE ZEROING

5.3.1 Zeroing Time

Prior to the start of a competition, competitors must be given the opportunity to zero their rifles on the range for a period of

45 minutes, which must begin one hour before and end no later than 5 minutes before the first start. At IBU events for the Pursuit, Mass Start and Relay competitions, a shorter time may be used but it must be at least 30 minutes and end 15 minutes before the start, and without paper target change. If necessary, Men and Women may both zero prior to the first competition, but this must be done separately.

5.3.2 Rifle zeroing may take place only on the range and only paper targets will be used for zeroing. Paper targets for zeroing must be placed at the same level and the same distance from the firing point as the competition targets. When two rows of paper targets are placed, the second row shall be below the level of the competition targets. If the paper targets have to be changed during zeroing, the time required for the change will not be deducted from the time allocated for zeroing.

5.3.3 Allocation of Zeroing Lanes

For Individual and Sprint competitions, each team should be allocated one zeroing lane on the range. The allocation of lanes will be determined by random draw conducted under supervision of the TD. For Relay competitions, the team zeroing lane is to be the same as the start number. For Mass Start competitions, the zeroing lane shall be allocated according to the start list, but the competitors will be free to zero from any lane allocated to a member of their NF. For Pursuit competitions, the shooting lane numbers shall be allocated according to the placement of the best ranked competitor of each team, but if a NF has more than 4 competitors starting, it shall be allocated 2 adjoining zeroing lanes. One reserve member of each team shall be permitted to zero before each competition, including the reserve Relay team member, except Pursuit and Mass Start competitions. Prior to the start of the Super Sprint Final competition, competitors must be given the opportunity to zero their rifles on the range for a period of 15 minutes, which must begin 20 minutes before and end no later than 5 minutes before the first start. If necessary, Men and Women may both be zeroed prior to the first Super Sprint Final competition but this must be done separately.

5.3.3.1 At the OWG, WCH and WC events the top 15 teams, based on the current Nations Cup Score standings, will be allocated lanes 1 to 15

by random draw, and the remaining teams' lanes will be separately drawn from the remaining lanes.

5.3.3.2 When a team has more than eight competitors, the OC may allocate an additional zeroing lane if available.

5.4 WARM-UP ON THE COURSE

For all IBU events, the course shall be open for warming up for entered competitors and team staff until five minutes before the start, unless otherwise decided by the Jury. All competitors on the course must wear their start numbers. From five minutes before the start, skiing on the course is forbidden, but team members may walk on the edge of the course.

5.5 SKI TESTING

It is forbidden to use electronic timing equipment on the competition course. Electronic ski testing must be done in the area designated for ski testing or on sections of the course that are not in use. In extraordinary circumstances the TD may authorize ski testing on the competition course. In such a case, electronic ski testing devices must be removed from the course at least 10 minutes before the start.

6. START REGULATIONS

6.1 START TYPES AND INTERVALS

6.1.1 General

There are four types of starts: single; pursuit; group and simultaneous; and two standard start intervals – 1 minute or 30 seconds. At all IBU events, the following regulations shall apply:

6.1.2 Individual and Sprint Competitions

For all Individual and Sprint competitions single starts will be made, normally with 30 second intervals. However, shorter or longer intervals shall be permitted if it is best for the competition. For the Sprint competition, group starts can be used. The TD together with the RD in consultation with the OC will decide which start type and start interval is the best for the circumstances.

6.1.3 Pursuit Competitions

In all Pursuit competitions, no standard start interval will be used. Competitors shall start at the exact time listed in the start list as

their start time, which is the length of time they finished behind the winner of the qualifying competition, rounded to the nearest second.

6.1.4 **Mass Start Competitions**

Start in the Mass Start competitions will be made in one single simultaneous start of all the competitors.

6.1.5 **Relay and Mixed Relay Competitions**

Start in Relay and Mixed Relay competitions will be made in a simultaneous start of the first competitor of each team. Subsequent starts of other team members will be made with a tag by the incoming team member in the Relay hand-over zone. The start sequence in the Mixed Relay is Woman, Woman, Man, Man.

6.1.6 **Super Sprint Competition**

6.1.6.1 Start in the Super Sprint Qualification Competition will be made as a single start – interval 15 seconds.

6.1.6.2 Start in the Super Sprint Final Competition will be made in one single simultaneous start of all the competitors.

6.2 **STARTING POSITIONS AND STARTS**

6.2.1 **Single Start with Electronic Timing**

Competitors shall stand as close to the gate as possible and will pass through the gate at their starting time.

6.2.2 **Single Start with Manual Timing**

If only manual timing is used, competitors shall stand with both feet completely behind the start line and will cross the line at their starting time.

6.2.3 **Pursuit Start**

Competitors must arrive in the start area at the time directed by the Competition Jury for placement into their start lanes. They will then be lined up sequentially in their start lanes. If a competitor is not present at the start, an OC official must stand in his place. Each simultaneous start must be from a separate lane. Physical inspection of each start will be done by an official located at the start line of each lane. The officials will bar the crossing of the start line by holding their arm horizontally across the end of the lane, and quickly lowering the arm at the exact start time for that lane. Competitors will start when they are the next in line and when the arm is dropped.

6.2.4 **Relay Start**

In Relay competitions the first starters will stand in their assigned start tracks with both feet on the line marking their start row, or beside their start position if no line is marked. They will cross the line when the designated start signal is given. Subsequent members of a Relay team will stand in the hand-over zone, according to the current competition's standing, and will start when tagged by the incoming team member.

6.2.5 **Group Start**

In group starts, the competitor with the lowest start number of that group shall take position 1, the second lowest position 2, etc. They shall stand as for the Relay simultaneous start and will start when the designated signal is given. This process shall be repeated for each group.

6.2.6 **Mass Start Competition Start**

The Mass Start competition will start in the same way as the first starters in the Relay simultaneous start.

6.2.7 **Super Sprint Competition Start**

The start order for the Super Sprint Qualification competition will be decided by the OC together with the IBU, for the respective competition. For the Super Sprint Final competition, competitors will be assigned start numbers and start positions based on the results of the Super Sprint Qualification competition. Competitors in the Super Sprint Final competition will start in the same order in which they finished the Qualification competition: the winner of the Qualification competition will start with start number 1, the second place of the Qualification competition will start with start number 2, and so on.

6.3 **START SIGNALS**

6.3.1 **Single Starts – Electronic Timing**

The start command shall be given by the sound of the start clock – a loud beep, and by the visual time on the start clock. The starter must not touch the competitor.

6.3.2 **Single Starts – Manual Timing**

At single starts without an electronic start gate, the starter shall say "Ready" 10 seconds before the time of start and then count down loudly from 5 seconds before the start, saying "Five-four-three-two-

one". At the exact start time, the starter shall give the command "Go". The starter must not touch the competitor.

6.3.3 Pursuit Starts

The start signal for each Pursuit start will be the dropped arm of the lane official.

6.3.4 Simultaneous and Group Starts

In the Relay, Mixed Relay, Mass Start competition, Sprint competition with group starts and Super Sprint Final, the start signal shall be given by a shot from a start pistol or another start device, or with a flag. Verbal warning signals will be given at 1 minute, 30 seconds and "Ready" prior to the start, with the start signal given within 5 seconds after "ready".

6.3.5 Start in the Hand-over Zone

In Relay competitions the Relay hand-over must take place within the hand-over zone in such a way that the arriving competitor touches the body (including torso, arms, legs, hands, feet and head) or the rifle of the outgoing competitor with his hand.

6.4 START TIME, EARLY START, LATE START AND FALSE START

6.4.1 Electronic Start Time

In single starts, the electronically recorded time of activating the gate shall be the start time if the competitors activate the gate within 3 seconds before or 3 seconds after the time designated in the start list. If a competitor starts more than 3 seconds before the scheduled time, it is an early start. If a competitor starts more than 3 seconds later than the scheduled start time, it is a late start and the time will begin from the scheduled time of start.

6.4.2 Manual Start Time

If only manual timing is used and the start is single, the time of start for competitors shall be the time stated in the start list. If a competitor starts before the start signal, it shall be an early start. If the competitor starts too late, it shall be a late start.

6.4.2.1 Pursuit Competition

The time of start for each competitor shall be the time listed in the start list. In the event of an early start, time adjustments or time penalties may be made by the Competition Jury. If a competitor

arrives too late at a start, the late competitor must be directed through the spare passage, and the official at that point will record the exact time when the competitor crosses the start line. If the competitor was late by his own or his team's fault, his competition time will be calculated from his official start time in the start list. If the cause of the delay was force majeure or incorrect or accidental actions of someone outside his team, his competition time and placement in the Pursuit will be calculated from the time recorded by the official.

6.4.3 Relay and Mass Start Competitions and Sprint Competitions with Group starts

The moment of start shall be at the time of the start signal.

6.4.4 Hand-over Zone Start Time

The start time for the Relay team member taking over shall be the moment when the incoming team member enters the hand-over zone by crossing the timing line at the beginning of the zone.

6.4.5 Early Start – Single and Relay Teams

If an early start occurs in a single competition or in the hand-over zone, the starter's assistant must stop the competitor as quickly as possible after the start line or the hand-over zone and send him back. The competitor must then return to behind the start line – or to the hand-over zone in Relay competitions – and start again. If possible, except in a Relay, the competitors will be restarted at their correct start time either through the gate or over the start line using manual timing. If the correct start time has already expired, the time of start shall revert to the listed start time. Time thus lost will count against the competitor.

6.4.6 False Start – Simultaneous, Group and Hand-over

If there is a false start during a simultaneous or group start, the IR and officials in charge will stop the competitors at the end of the set parallel tracks. After a false start, there must be a new start. If the Relay hand-over occurs before or after (outside) the hand-over zone, it shall be a false start and the procedure must be repeated within the zone. A competitor or Relay Team will be considered as having not started if they have made a false start and do not return to start again, correctly.



6.4.7 Late Start

If competitors are late to the start, they must start at the first possible opportunity as directed by the starter, without obstructing other competitors.

6.4.7.1 If the competitor was late due to his own fault, his start time will be the one on the start list. If the late start was due to force majeure, the Competition Jury will decide his start time.

6.5 START NUMBERS

6.5.1 General

At all IBU competitions, all competitors must wear a bib which has their start number on it. Competitors must also wear their start number on both thighs. Competitors are responsible to ensure that their start numbers remain attached to the required positions during a competition. The start number and sequence color worn by a competitor must be the number and color assigned for that competitor for that competition by the competition start list.

6.5.1.1 Numbering

At OWG, WCH, and WC competitions, the set of start numbers for Men and Women for each start must begin with the number 1 and must continue in numerical sequence to the last number.

6.5.1.2 Color

The color of the start numbers must clearly contrast against the base color of the cloth.

6.5.1.3 Sizes of Start Numbers

The sizes which must be used for start numbers in IBU competitions are detailed in the Material Catalogue.

6.5.2 Start Number Colors by Competitions

6.5.2.1 Individual, Sprint, Pursuit, Mass Start and Super Sprint Competitions

The start numbers of all competitors shall be of the same design.

6.5.2.2 Relay Competitions

The start number colors within the team shall be red for the starting member, green for the second, yellow for the third and blue for the fourth.

6.6 WEATHER CONDITIONS

6.6.1 Temperature

Biathlon competitions must not be started if the air temperature is colder than minus 20 degrees Celsius measured at the coldest part of the site (range or course), 1.5 m above ground.

6.6.2 Wind Chill

Regardless of temperature, wind chill must be considered before starting and during the competition. In the case of a high wind chill factor, the Competition Jury, in consultation with the IBU Medical Delegate or the Competition Physician, will decide whether to start or continue the competition. Changing of the course to be skied may also be done to avoid windy areas. The following Table 2 shows wind chill temperature equivalents.

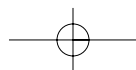
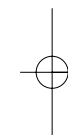

**TABLE 2 - WIND CHILL TEMPERATURE EQUIVALENTS
WIND SPEED IN KM/H**

Wind Speed	Temperature in °C (Degree Celsius)												
	10	5	0	-5	-10	-15	-20	-25	-30	-35	-40	-45	-50
10 km/h	8,6	2,7	-3,3	-9,3	-15,3	-21,1	-27,2	-33,2	-39,2	-45,1	-51,1	-57,1	-63,0
15 km/h	7,9	1,7	-4,4	-10,6	-16,7	-22,9	-29,1	-35,2	-41,4	-47,6	-53,7	-59,9	-66,1
20 km/h	7,4	1,1	-5,2	-11,6	-17,9	-24,2	-30,5	-36,8	-43,1	-49,4	-55,7	-62,0	-68,3
25 km/h	6,9	0,5	-5,9	-12,3	-18,8	-25,2	-31,6	-38,0	-44,5	-50,9	-57,3	-63,7	-70,2
30 km/h	6,6	0,1	-6,5	-13,0	-19,5	-26,0	-32,6	-39,1	-45,6	-52,1	-58,7	-65,2	-71,7
35 km/h	6,3	-0,4	-7,0	-13,6	-20,2	-26,8	-33,4	-40,0	-46,6	-53,2	-59,8	-66,4	-73,1
40 km/h	6,0	-0,7	-7,4	-14,1	-20,8	-27,4	-34,1	-40,8	-47,5	-54,2	-60,9	-67,6	-74,2
45 km/h	5,7	-1,0	-7,8	-14,5	-21,3	-28,0	-34,8	-41,5	-48,3	-55,1	-61,8	-68,6	-75,3
50 km/h	5,5	-1,3	-8,1	-15,0	-21,8	-28,6	-35,4	-42,2	-49,0	-55,8	-62,7	-69,5	-76,3
55 km/h	5,3	-1,6	-8,5	-15,3	-22,2	-29,1	-36,0	-42,8	-49,7	-56,6	-63,4	-70,3	-77,2
60 km/h	5,1	-1,8	-8,8	-15,7	-22,6	-29,5	-36,5	-43,4	-50,3	-57,2	-64,2	-71,1	-78,0

NOTES TO TABLE 2

1. This is only a guide - the decision to start or not will be made by the Competition Jury in consultation with the IBU Medical Delegate or the Competition Physician.
2. Wind speed is to be measured at height of 1.5 m on the range.
3. Temperature is measured at 1.5 m at the coldest point in the competition area.

7. SKIING REGULATIONS**7.1 GENERAL****7.1.1 General Skiing Rules**

Competitors must ski the entire distance of the stipulated competition course in the correct sequence and direction on skis, carrying their rifle and the required number of rounds, and following the marked course precisely. They may use no other form of propulsion than skis, poles and their own muscular force. All skiing techniques shall be permitted. As required for timing and other sensor purposes, competitors must carry the electronic transponder device(s) provided by the event timing firm, during the competition, attached to one or both ankles as directed. The transponder may not be removed until the official removal place after the competition. The transponder must be of such design that it does not interfere with the competitors' movements in the competition. Maximum weight of a transponder may not exceed 25 gm each.

7.1.1.1 Did Not Finish

If a competitor withdraws from the competition before the finish, he must inform the first official he meets and is responsible for returning the transponders and the start number to the finish equipment/material and clothing inspection area as soon as possible.

7.1.2 Carrying the Rifle

The rifle must be carried on the back, with the barrel pointing up. If the rifle is so damaged during the competition that it can not be carried on the back, it must be safely carried in hand to the shooting range and then must be immediately exchanged for the team reserve rifle.

7.1.3 Wrong Course Section

If a competitor skis on a wrong course section, which would result in a time advantage or the wrong sequence, he must return to the point where he made the wrong turn, along the part of the course he skied in error. In order to do so, the competitor may have to ski against the correct ski direction and shall be totally responsible for ensuring that he does not obstruct or endanger other competitors. There will be no penalty for having committed the error as long as no time advantage has been gained and there has been no interference with other competitors.

7.1.4 Passing and Giving Way

A competitor who is in position to pass another competitor, and wishes to pass, will yell "Track". A competitor who is about to be overtaken must clear the course in front of the passing competitor at the first yell of "Track" or other voice signal, even if the course is wide enough. However, this obligation does not apply to the last 50 m before the finish line and the last 50 m before the hand-over zone.

7.1.5 Skiing Penalty Loops

In all competitions in which the shot-penalty is the 150 m penalty loop, the competitors must ski the loop once for every missed target immediately after the shooting bout.

7.1.5.1 Responsibility

Competitors themselves shall be responsible for skiing the required number of penalty loops immediately after the shooting bout. It is not permitted to complete penalty loops at a later time.

7.1.5.2 Penalty Loop Error

If competitors, due to a mistake by the OC or a target malfunction, ski too many penalty loops, the Competition Jury shall decide on an appropriate time allowance. The OC shall ensure, in each competition in which the penalty loop is used, that the average penalty loop ski time is recorded, based on at least five competitors.

7.1.6 Skating at Relay, Mass and Group Starts

The use of the skating technique (one or both legs sideways) is prohibited in the tracked portion after the start line in simultaneous or group starts.

7.2 OBSTRUCTION

It is strictly forbidden to impede other competitors in any way at any time during the competition. This prohibition also includes the dropping of objects on the competition course or the shooting range in such a way that it obstructs other competitors.

7.3 EXCHANGING EQUIPMENT, REPAIRS, ASSISTANCE**7.3.1 Exchange of Skis and Poles**

A competitor may exchange one of his skis, but only if it is broken or the binding is damaged. Broken poles and straps may be exchanged

repeatedly. The replacement skis and poles must be in conformity with the IBU Material Catalogue rules.

7.3.2 Glide Performance and Equipment Repairs

The competitors may not change the glide performance of their skis by the application of any substances during a competition. They may repair their equipment during a competition, provided they receive no assistance from any person.

7.3.3 Rifle Repairs, Exchange and Ammunition

Assistance to repair a rifle shall only be permitted on the shooting range, by the Competition Armourer or a competition official on the shooting range. A rifle may be exchanged only on the shooting range. Competitors shall be permitted to receive ammunition on the course and the shooting range.

7.3.4 Refreshments

Competitors may consume refreshments during the competition. The refreshments may be carried by the competitors or be given to them.

7.3.5 Other Assistance

Competitors are not permitted to receive any assistance from any person, other than as expressly stated in these Rules.

8. SHOOTING REGULATIONS**8.1 GENERAL****8.1.1 Shooting Rules**

All shooting during training and competition shall take place at the shooting range. In a competition competitors shall shoot after having completed each of the required sections of the course for the competition, except the last section which shall end at the finish or the Relay hand-over. The shooting specifications for all competitions are given in Table 1 under 1.3.8. When a rifle is taken out of the stadium area, it must be in a case or a cover bag.

8.2 SPECIFIC SHOOTING RULES FOR TYPES OF COMPETITIONS**8.2.1 Selection of Shooting Lanes**

In Individual and Sprint competitions, shooting lanes may be freely chosen by the competitor from among the targets that are ready in

the correct sequence (prone or standing). In the Pursuit, Individual and Sprint with group start competitions, the competitors must go sequentially in the shooting lanes starting with lane 1 and taking the lowest available number, until the last shooting lane is reached, at which time the next competitor must go to lane number 1 and the process begins again. For the Mass Start, in the first shooting bout the competitors must shoot from the lane number designated by their start number and for subsequent bouts by filling in the range sequentially from the right in the order of arrival on the range. In Relay competitions, the shooting lane designated by the team's start number must be used for the first shooting bout of the first competitor of each team and after that the range will be filled in sequentially from the right in the order of arrival on the range.

8.2.2 Relay Competitions – Spare Rounds

In the Relay competition, each competitor must fire the first 5 rounds and if targets remain standing he must use the 3 spare rounds until all 5 targets are hit or until all 8 rounds are fired. If the spare rounds are needed after having fired the first 5 rounds, the spare rounds must be hand loaded one by one – not loaded directly from a magazine.

8.3 SHOOTING POSITIONS

8.3.1 Prone Position

In the prone position the competitors must comply with the following regulations: the rifle may only be in contact with hands, shoulder and cheek. The lower side of the wrist of the arm supporting the rifle must be distinctly raised from the ground (snow surface). The other arm may touch the ground for a maximum length of 10 cm from the elbow.

8.3.2 Standing Position

In the standing position the competitors must comply with the following regulations: they must stand without any support. Only hands, shoulder, cheek and the chest next to the shoulder may be in contact with the rifle. The arm supporting the rifle may be held against the chest or put onto the hip.

8.3.2.1 No Removal of Skis

It is prohibited to remove one or both skis while shooting, including training and zeroing, or to place any kind of objects under the skis.

8.3.3 Position in Shooting Lane

The competitor must ensure that no part of his body, clothing, materials or equipment protrudes over the 1.5 m red lines marking the shooting lane or the extension of those boundaries while shooting. The competitor must also ensure that the rifle muzzle extends over the firing line.

8.3.4 Enforcement

If a competitor is warned by a Range Official that his shooting position or his position in the shooting lane is not according to the rules, the competitor must immediately make the correction.

8.4 SHOOTING AIDS

8.4.1 Use of Shooting Sling and Arm Cuff

The use of a shooting sling and arm cuff is permitted in both the prone and standing positions.

8.4.2 Use of Magazine

The five rounds required in each bout of shooting may be loaded with the use of a magazine. If rounds are lost from the magazine or fail to fire, a new magazine may not be inserted into the rifle. Such rounds must be loaded individually. However, if a magazine is lost or defect, it may be replaced with another magazine.

8.5 SAFETY REGULATIONS

8.5.1 General

Shooting shall be permitted only on the shooting range, during officially authorized times. It is forbidden to make movements with a rifle which might endanger persons, or which may be perceived by others as dangerous. The rifle muzzle must be over the forward edge of the shooting ramp (= firing line) from the beginning to the end of the shooting stage. When the range is open for shooting, no one shall be permitted to be forward of this line. TV crew members and photographers shall take responsibility for their own safety if they enter this area. At all times, the competitor shall be responsible for the safety of his actions and rifle.

8.5.2 Loading and Unloading

The rifle may be loaded and unloaded only with the barrel pointing in the direction of the targets or up. To insert a magazine containing bullets into the rifle is also part of the loading procedure. When

moving from one shooting lane to another, the competitor must first unload his rifle and place the rifle on his back in the normal carrying position.

8.5.2.1 Safety Check on the Range after Shooting

After each shooting bout the rifle must be unloaded – that is, no round may be left in the chamber or in the inserted magazine. However, it is permitted to leave the cartridge case in the chamber and the empty magazine in the rifle after the last shot. At the end of training and/or zeroing sessions, the competitor must perform a safety check before leaving the shooting range by opening the bolt and removing the inserted magazine, with the barrel pointed toward the target or upward.

8.5.3 Aimed Shots

All shots must be aimed and fired only at the targets.

8.5.4 Removal of Rifle on the Range

A competitor may not remove a strap of his rifle carrying harness from his shoulder before he has reached the firing lane from which he will shoot. He must cross the lane marking line with both feet and lay both ski poles on the ground prior to removing his rifle from the carrying position.

8.5.5 Safety at the Finish

At all IBU competitions there must be one or more official(s) at the end of the finish area who will open the rifle action of every competitor. This check may only be performed when the rifle is pointing upwards. At the same time, the official will inspect the cartridge case ejected from the chamber. If this safety check is not done, the competitor must do it himself.

8.6 MISFIRES, LOST ROUNDS/MAGAZINES AND DAMAGED RIFLES

8.6.1 Misfires and Lost Rounds/ Magazines and Damaged Rifles

Misfired or lost rounds, or magazines, may be replaced by a competitor if he is carrying spare rounds or magazines. If he is not carrying spare rounds or magazines, replacement rounds or magazines may be obtained by the competitor from a Range Official by raising a hand and saying "Bullets" and the name of his NF

loudly. The Range Official who responds will get the spare rounds from the team's reserve rifle or from the team's support staff behind the range and deliver them to the competitor. Competitors are permitted to receive ammunition and magazines on the course as well.

8.6.2 Damaged Rifles

If a rifle needs to be repaired, the competitor may do the repairs or may accept assistance, but only from the Competition Armourer or a Range Official. If the rifle cannot be made functional, it may be exchanged for the team's reserve rifle.

8.6.2.1 Reserve Rifle

A rifle which has been damaged during the competition or malfunctions for technical reasons to such an extent that it cannot be used to continue the competition may be exchanged for a team reserve rifle which has been inspected and marked at the equipment check and deposited in the designated reserve rifle rack on the range before the competition by the team. The competitor must then continue the competition with the reserve rifle.

8.6.2.2 Rifle/Magazine/Ammunition Exchange Procedure

If the rifle has been damaged or a magazine lost on the course, the competitor himself may ski to the team reserve rifle in the rack on the range, prior to going to the shooting lane, and exchange his rifle or replace his magazine, and then continue to his shooting lane. During shooting the competitor shall indicate that his rifle needs to be exchanged by raising his hand. When a Range Official responds, the competitor will point to his rifle and say "Rifle" and the name of his NF loudly. The Range Official will obtain the team's spare rifle from the designated rifle rack and bring it to the competitor.

8.6.3 No Time Adjustment

There shall be no time adjustment for repairing or exchanging a rifle or obtaining a spare magazine or rounds.

8.6.4 Response by Range Officials

All Range Officials must be alert to observe a raised hand or a yell by a competitor to ask for spare rounds or rifle exchange. The Range Officials must react with a sense of urgency and move quickly to minimize the time required to bring the rounds or to exchange the rifle.

8.7 TARGET ERRORS AND MALFUNCTIONS

8.7.1 Incorrectly Set Target

If a competitor is confronted with an incorrectly set target, standing for the prone position or vice versa, the incorrect target shall be set to the correct position immediately. The competitor will then commence shooting from the beginning.

8.7.2 Target Malfunction

If a target fails to function, the competitor must be directed to another target and the defective target must be blocked off immediately. The range official will inform the competitor whether he should continue the shooting bout or recommence shooting from the beginning.

8.7.3 Cross-firing and Target Hit by Another Competitor

If the target on which a competitor is shooting is fired on by another competitor, the one shooting incorrectly must be stopped immediately. If no target plates have fallen, the correct competitor may continue shooting. If a target plate has been hit, the target must be reset immediately and the competitor shall then continue shooting.

8.7.3.1 Before such a target is reset, the hits and their positions must be recorded. In such a case in the Sprint, Pursuit, Mass Start or Relay competition, the competitor must be told by the Range Official how many penalty loops must be done.

8.7.3.2 If a competitor cross-fires onto a target not in his shooting lane, and no other competitor is shooting on that target, he shall be allowed to continue without the mistake being pointed out to him. The competitor's hits will be only those which are on the correct target.

8.7.4 Time Adjustments and Responsibility

In those cases where a competitor loses time due to a target error which is not his fault or a target malfunction, the Competition Jury shall make an appropriate time adjustment.

8.7.4.1 Own Error

If, however, a competitor makes an error such as cross-firing or selecting a target which has been used and not reset, he shall be responsible and no time adjustment will be made.

8.7.5 Scoring of Shooting

For all shooting in competitions, a system of scoring the shooting must be put in place by the OC. Each shot that is fired in a competition must be observed by three independent persons or methods. For OWG, WCH and WC competitions, the system shall consist of the electronic target scoring device and two separate observations by Range Officials.

9. THE FINISH, COMPETITION TIME AND RESULTS

9.1 THE FINISH

9.1.1 Moment of Finish

Finish is the moment when a competitor's or a Relay team's competition time ends. When electronic timing is used, the finish will occur when the beam of the electronic sensor at the finish line is broken by the competitor. When manual timing is used, the finish will occur when the competitor crosses the finish line with one or both feet. In Relay competitions the timing is to be taken from the last member to finish.

9.2 COMPETITION TIME

The competition time is the period of elapsed time during the competition on which the placing of a competitor or Relay team in the results of the competition are based. The time always includes any penalties or adjustments imposed or awarded by the Competition Jury.

9.2.1 Individual Competitions

In Individual competitions, the competitor's time will be the elapsed time between start and finish plus any shot-penalty minutes imposed.

9.2.2 Sprint, Pursuit and Mass Start Competitions

In Sprint, Pursuit and Mass Start competitions the competitor's time will be the elapsed time between start and finish. In the Pursuit competition and the Mass Start competition, the first competitor to cross the finish line, subject to penalties and time adjustments, shall be declared the winner. This also applies to the rankings of subsequent finishers.

9.2.3 Overtaken competitors in Pursuit and Mass Start competitions

At OWG, WCH and WC, in Pursuit and Mass Start competitions if the leading competitor laps a competitor on the course, the overtaken competitor must withdraw from the competition at a suitable area in connection with the shooting range.

9.2.4 Relay Competitions

In all Relay competitions the competition time of a team member shall be the elapsed time from the start, or hand-over, to the next completed hand-over or from the hand-over to the finish. The total time of a Relay team is the time elapsed between the start of the first member to the finish of the last member. The time of the incoming member stops when he crosses the timing line into the hand-over zone and the time of the outgoing member begins at the same moment.

9.2.4.1 Placing in Relay competition

The placings of Relay teams in the results shall be decided by the order of finish of their respective last competitors, subject to time penalties or time adjustments.

9.2.5 Equal Time – Tie

If two or more competitors have the same competition time, they shall be placed in the results with equal (tie) rankings. At OWG, WCH, Y/JWCH and WC in Pursuit, Mass Start and Relay competitions, if analysis of the photo-finish camera data cannot resolve the order of finish of two or more athletes then a tie shall be declared. Equal placings (tie) in a competition shall be given an equal number of points.

9.2.6 Photo-Finish

At OWG, WCH, Y/JWCH and WC in Pursuit, Mass Start and Relay competitions, a photo-finish camera must be installed at the finish line to record the finish. The camera must be placed exactly in line with the finish line and in such a position that the entire finish line is seen by the camera. If the photo-finish record is required to decide the order of finish, the order in the photo-finish record shall determine the placings. The decision shall be based on the first part of the first foot crossing the finish line. The IR Start/Finish shall be the photo-judge and shall decide the finish order based on the photo-

finish record. Photo-finish is not mandatory at CCH or CC competitions but may be used.

9.2.6.1 Finish Video Camera

At OWG, WCH, Y/JWCH and WC events a video camera must be installed at the finish in such a way that it will record the start numbers of competitors as they cross the finish line. Such a system is recommended for all other events as well.

9.2.7 Intermediate Times

At OWG, WCH, Y/JWCH and WC competitions, times after each bout of shooting must be available to the electronic information board, the media and teams. An intermediate timing line will be set after the penalty loop (or after the range for the Individual competition) and each competitor's time shall be recorded after each bout of shooting.

9.3 TIMING SYSTEMS

9.3.1 Requirements

Competition time must be measured electronically, backed by manual timing. Manual timing shall be used only if the electronic system fails during the competition. Specifications of timing equipments are given in the IBU Material Catalogue (Annex A).

9.3.2 Units of Measurement

Electronically and manually measured competition times must be registered to 1/10 (0.1) of a second.

9.4 THE COMPETITION RESULTS

9.4.1 General

Results are the record of the performance of the competitors or teams in a competition. The OC shall be responsible for producing and distributing the results on paper and electronically. At all IBU events, English must be used in the results, however, more than one language may be used in the same results. Provisional and Final Results must include the following information:

- Name and location of the event;
- Type, time and date of the competition;
- Course and weather data;
- Names of the Competition Jury members;
- Signature of the TD;

- f. Number of entered competitors and total ranked;
- g. Number of those who did not start and did not finish;
- h. Notes about imposed penalties: article, time adjustment or kind of penalty;
- i. Columns for:
 - placings, in ranking order from first to last;
 - start numbers;
 - last and first names of competitors;
 - NF or team;
 - shooting penalties per bout;
 - shooting penalties, total;
 - ski times to 1/10 (0.1) second;
 - total time, and team time in Relay;
 - time behind;
 - World Cup points (when appropriate);
 - Nations Cup points (when appropriate).

For the Pursuit Competition the times shown will be the time behind the first starter for the winner, followed by the time behind the winner for the remaining competitors.

9.4.1.1 Ties

If there is an equal competition time, the tied competitors shall be given equal ranking and equal points in the results, however, there shall be no next placing in the results.

9.4.2 Types of Results

There are three types of results: Intermediate, Provisional and Final.

9.4.2.1 Intermediate Results

Intermediate Results reflect the competition situation during the competition and are for information only. They will be displayed on the score board, announced by the public announcer and will be available through the electronic information system.

9.4.2.2 Provisional Results

Provisional Results are the first official record of the competition produced by the OC after the last finish. Provisional Results are always subject to protest and must be published and posted at the finish area and competition office as soon as possible after the finish of the last competitor. The TD must sign and write the time of

posting on the Provisional Results List so that the end of the protest period will be clear.

9.4.2.3 Final Results

The Final Results are the uncontested final record of the competition and must be published immediately after the deadline for protests has passed, or as soon as the Competition Jury has made its decisions on protests which were submitted.

9.4.3 Results Booklet

The Final Results and other important information about all the competitions for all IBU events must be made into a booklet. The booklet must contain:

- a. the event program;
- b. participant list - NFs, competitors, trainers;
- c. decisions of the Competition Jury and Jury of Appeal;
- d. all Final Results, with applicable points lists and title page.

All results pages of the booklet must be on white paper only.

9.4.4 Distribution of Booklets and Results

At all IBU events, one copy of the Results Booklet must be distributed to all NFs that have participated in the event. If this cannot be done before their departure, the booklet must be sent by mail as soon as it is ready. A copy of the Results Booklet must be sent to the SG of the IBU. In addition, the Results Booklet, and CD, produced at the WC Final must be sent to all NFs that have participated in any WC event during the season. One copy of each results list and meeting minutes as well as analysis after each competition shall be distributed to the mailbox of each participating NF. Additional copies shall be available at the competition office upon request.

10. PROTESTS

10.1 GENERAL

Protests must be submitted in writing, using the official IBU Protest Form, to the Competition Secretary, for the Competition Jury, and must be accompanied by a fee of EUR 50, or equivalent in the currency of the host NF. The IBU protest form can be obtained from the Competition Secretary. If the protest is upheld, the money shall be paid back. If the protest is rejected, the money will go to the IBU.

10.2 PROTEST TYPES AND CONDITIONS**10.2.1 Eligibility Protests**

Protests concerning the eligibility of a competitor may be submitted at any time up to the end of the protest time for the competition in question.

10.2.2 Protests During and After Competitions

Protests concerning violation of rules by competitors and team staff, mistakes made by officials, competition conditions and the Provisional Results must be submitted in the time period between the start of zeroing for the competition until 15 minutes after the posting of the Provisional Results. A clear announcement must be made by the OC immediately after the posting of the Provisional Results to inform everyone that they have been posted.

10.2.3 Repetition or Annulment

If the examination of a protest reveals circumstances which are so serious that they make the sporting value of the competition doubtful, or if the Competition Jury from its own observation comes to the same conclusion, the Competition Jury may decide to repeat the competition or to annul the competition without repetition.

11. PENALTIES

For penalties, refer to the IBU Disciplinary Rules.

12. WORLD CHAMPIONSHIPS – EVENT RULES**12.1 GENERAL REGULATIONS****12.1.1 Jurisdiction and Terms**

The WCH and Y/JWCH are IBU events and shall be held under its jurisdiction for Men, Women, Junior Men and Junior Women, and for Youth Men and Youth Women. In this section the rules stipulated for WCH shall also apply to the Y/JWCH unless a specific difference is indicated.

12.1.2 Event Dates

WCH shall be held for Men and Women together annually during dates approved by the IBU EB, but shall not be held during years of the OWG. Y/JWCH for Junior Men and Junior Women and for Youth Men and Youth Women together shall be held annually during dates

approved by the IBU EB. If any IBU authorized competition is not in the program of the OWG, a WCH competition shall be held for it in years of the OWG.

12.1.3 Best Biathletes – Financial Responsibility and Selection

Each OC of the WCH must pay the accommodation and meal expenses for the best male and the best female Biathletes for a maximum of twelve days during the WCH according to the numbers of Biathletes set by the IBU EB. Selection of the best Biathletes at the WCH will be from the top rankings of the current WC Total Score prior to the start of the WCH.

12.2 BIDS TO HOST AND APPOINTMENT OF HOSTS**12.2.1 General**

The task of organizing the WCH shall be entrusted to a Member Federation of the IBU, for the appointed location, by the IBU Congress at least four years and not more than five years in advance.

12.2.2 Application to Host a WCH

The bid to host a WCH must be submitted by a NF wishing to host to the IBU SG in writing, and the application must be received not later than 90 days before the applicable IBU Congress. The site for which the bid is made must have a current IBU license. The application must be submitted using the official IBU application form and must be signed by the NF President or SG.

12.2.3 The IBU Event Hosting Declaration

After a host for a WCH has been appointed, the hosting NF must sign the IBU Event Hosting Declaration. By signing, the hosting NF shall testify that it accepts and will fulfill, in the required time, the tasks, measures and duties stipulated in the Declaration.

12.3 EVENT SCHEDULE AND PROGRAM

The proposed event schedule and program will be established by the OC in consultation with the TD and submitted to the IBU Headquarters at least two years prior to the start of the event. The program must be submitted to the TC for review and must be approved by the IBU EB at the latest one year prior to the start of the WCH.

12.4 PROGRESS REPORTS

The OC must report regularly about its progress to the IBU.

12.5 INFORMATION BULLETINS AND INVITATIONS**12.5.1 Preliminary Information**

At least one year prior to the WCH, the OC must send a preliminary information bulletin to all IBU Member Federations and to the IBU Headquarters. The bulletin must provide all significant information about the WCH which is required by the NFs at that time.

12.5.2 Official Invitation

Not later than 1 September of the year preceding the WCH, the OC must send the official invitations to all IBU NFs and to the IBU Headquarters. NFs which require a special invitation for visa purposes must request them from the OC.

12.5.3 Final Bulletin

Not later than 15 October prior to the WCH, the OC must circulate a detailed information bulletin to all IBU NFs and to the IBU Headquarters. The bulletin must provide detailed information in accordance with the Organizers' Guide.

12.5.4. Electronic Bulletins and Invitations

Bulletins and invitations may be sent in electronic form by e-mail and by placing it on a website, with notification by e-mail.

12.6 PARTICIPATION**12.6.1 Quotas - WCH****12.6.1.1 Maximum Registration and Entries**

Each NF in good standing shall have the right to register a maximum of 8 male and 8 female competitors and to enter 4 male and 4 female competitors in the Individual and Sprint competitions. Additionally, the NFs of the Individual, Sprint and Mass Start champions of the previous year's OWG or WCH will be granted the right to enter those competitors at the WCH Individual, Sprint and Mass Start competitions respectively, in addition to their NF's quota.

12.6.1.2 Pursuit Competitions

The top 60 competitors from the qualifying competition shall be entitled to start in the Pursuit competition.

12.6.1.3 Mass Start Competitions

The Mass Start competition entries shall consist of 30 competitors, selected as follows: the top 15 from the WC Total Score plus any medal winners that are not among the top 15 in the WC Total Score, then the points acquired in the Individual, Sprint and Pursuit competitions of the WCH being held, in ranking order. Start numbers shall be assigned in the order as follows: the gold medalist of the first personal competition of the WCH shall receive start number 1; the gold medalist of the second personal competition shall receive number 2; and the gold medalist of the third personal competition shall receive number 3, with the silver medalists of the personal competition receiving start numbers in the same order beginning with start number 4 – 6, and bronze medalists in the same way beginning with start number 7 – 9. The top competitors in the current WC Total Score will receive start number 10, and so on. If a competitor has won more than one medal in the personal competitions of the WCH being held, he will receive the lowest start number in keeping with the above sequence and other competitors will move up in the same order, and the same principle shall apply if more than one competitor wins multiple medals, or if one or more competitors are missing.

Four competitors will be the maximum number of entries for any NF. However, if an NF has more than four medalists, then all medalists of this NF will be entitled to start. In addition to the NF's quota, the champion of the previous year's OWG or WCH in Mass Start will be allowed to be entered. Unless he is not already selected in accordance with the above rule, he shall receive start number 30.

12.6.1.4 Relay Competitions

The best 30 NFs, for Men and Women, may enter Relay teams based on the previous year's Nations Cup Score.

12.6.1.5 Mixed Relay Competitions

A maximum of 30 Mixed Relay Teams shall be allowed to participate, based on the sum of the NF's current Nations Cup Score for Men and Women.

12.6.1.6 Team Staff

NFs shall be allowed to register team staff according to the number of competitors they registered. If this number is 4 or less, they shall be allowed to register a maximum of 4 team staff members.

Starting from 5 competitors the maximum number of team staff that may be registered shall equal the number of competitors registered by the respective NF. If the OC is able to accept more than this number, the number must be stated in the invitation along with the conditions for the extra staff.

12.6.2 Quota – Y/JWCH

12.6.2.1 Maximum Registration and Entries

Each NF may register a maximum of five each of Junior Men and Junior Women, and five each Youth Men and Youth Women for the Y/JWCH. Entries for specific competitions at Y/JWCH shall be as follows:

12.6.2.2 Individual and Sprint Competitions

A maximum of four competitors per NF may be entered for each Junior Men, Junior Women, Youth Men and Youth Women. Additionally, the NFs of the Individual and Sprint champions of the previous year's Y/JWCH shall be granted the right to enter them at the Y/JWCH Individual and Sprint competitions in addition to their NF's quota, as long as the competitors are still in the same class as they were at the previous Y/JWCH.

12.6.2.3 Pursuit Competitions

The top 60 competitors from the qualifying competitions will be entered for each of the competitions Junior Men, Junior Women, Youth Men and Youth Women.

12.6.2.4 Relay Competitions

Each NF shall have the right to enter one Relay team per class for the Y/JWCH Relay competitions. A competitor may start in one Relay only (Youth or Junior).

12.6.2.5 Team Staff

Article 12.6.1.6 shall apply accordingly.

12.7 AWARDS

12.7.1 Official Medals

Competitors placed first, second and third in the Individual, Sprint, Pursuit and Mass Start competitions shall be awarded the IBU medal in gold, silver and bronze, respectively. Each member of the Relay teams placed first, second and third shall be awarded the IBU medal, in gold, silver and bronze, respectively.

12.7.1.1 Awards Ceremony

The presentation of the official World Championships medals must include flag raising and national anthems. Competitors may not appear with their competition materials/equipment.

12.7.1.2 Flower Ceremony

The flower ceremony is the presentation of the top 8 competitors and top 6 Relay teams immediately after the end of the competition. The competitors shall appear wearing their competition start numbers and may have with them their competition materials/equipment.

12.7.2 Other Prizes

The Organizing Committee and other bodies may present other prizes.

12.8 LEADER START NUMBERS

The competitors, both Men and Women, who are the best ranked in the current World Cup Score for the Individual, Sprint, Pursuit and Mass Start competitions shall wear a numbered "World Cup Leader" start number during the World Championships instead of a conventional start number.

The World Cup Leader Bib colors are:

- a) Total Score leaders – yellow
- b) Individual, Sprint, Pursuit, Mass Start leaders – red
- c) Total Score leaders who are at the same time best ranked in the respective competition type – yellow/red combined.

13. THE OLYMPIC WINTER GAMES – EVENT RULES

13.1 RULES

The IOC has jurisdiction over the OWG; however, these Event and Competition Rules shall apply for the OWG except when otherwise stipulated by IOC regulations. For the Mass Start competition at OWG, the World Championships Event Rules shall apply accordingly, except that the previous year's world champion shall not be allowed to start in addition to the NF quota unless otherwise qualified.

13.2 SCHEDULE AND PROGRAM

The event schedule and program for the competitions will be established by the OC in consultation with the TD and Assistant TD. The schedule and program must be submitted to the TC for review and must be approved by the IBU EB.

14. CONTINENTAL CHAMPIONSHIPS AND CONTINENTAL CUPS – EVENT RULES

14.1 CONTINENTAL CHAMPIONSHIPS

14.1.1 General

The CCH are IBU events that are organized under its jurisdiction jointly for Men, Women, Junior Men and Junior Women. These rules shall apply to the following championships:

- a. Asian Championships (ACH)
- b. European Championships (ECH)
- c. North American Championships (NACH)
- d. South American Championships (SACH).

FOR CCHs, the host will be appointed two years in advance of the event by the EB based on recommendations by the TC. ECH are subject to an event hosting declaration.

14.1.2 Inspection

The immediate inspection is to be exercised by an IBU TD whose expenses are to be paid by the OC.

14.1.3 Competition Types

The following competition types shall be authorized for CCH: Individual, Sprint, Pursuit, Mass Start and Relay. All official IBU classes of competitors will be authorized to participate as set by the respective NFs of the continent.

14.1.4 Eligibility and Participation

Biatletes of all IBU member NFs shall be eligible to participate. However, only members of the teams of the host continent NFs shall be eligible to be Continental Champions and medalists. Participation quotas will be set by the respective NFs of the continent.

14.1.5 Competition Rules

The IBU Event and Competition Rules shall apply to the CCH. Special rules may be prepared and set by the respective NFs of the continent. CCH rules are detailed in Annex D.

14.1.6 Awards

Official IBU medals will be awarded to the competitors as follows: first place – gold; second – silver; third – bronze. Additional prizes may be awarded by the respective NFs of the continent.

14.2 CONTINENTAL CUPS

14.2.1 General

The CC are IBU events that are organized under its jurisdiction. They can be organized as joint event series for Men, Women, Junior Men, Junior Women, Youth Men and Youth Women. The CCH rules shall apply to CC with the following exceptions.

The following CC Series are authorized:

- a. Asian Cup (AC)
- b. European Cup (EC)
- c. North America Cup (NAC)
- d. South America Cup (SAC).

14.2.2 Not to be Held Together with WC

The CC are separate events and may not be organized at the same venue together with WC competitions.

14.2.3 Event Hosting Applications and Appointment of NFs

Each IBU member NF may apply to organize one or more CC event(s) a season. Applications must be submitted to the IBU SG by the deadline established by the EB. The host NFs will be appointed by the IBU EB based on recommendations of the TC.

14.2.4 Competition Rules

The IBU Event and Competition Rules shall apply to the CC. Special rules may be prepared and set by the respective NFs of the continent. The CC competition rules are detailed in Annex E.

14.2.5 Juries

Only Competition Juries will be established, under IBU jurisdiction, for CC events. NFs of the continent may establish a Jury of Appeal for events.

15. WORLD CUP – EVENT RULES

15.1 GENERAL REGULATIONS

15.1.1 Jurisdiction

WC are IBU events and shall be held under its jurisdiction for Men and Women. These Rules shall apply for WC events.

15.1.2 TD and IR Expenses

The travel, accommodation and meal costs, and daily allowance of

the IBU TD and IRs shall be borne by the OC for the period they are required for the event, in accordance with the current IBU Rules for Travel Expenses.

15.1.3 Best Biathletes – Financial Responsibility and Selection

Each OC of a WC event must pay the accommodation and meal expenses for the best male and the best female Biathletes for a maximum of seven full days for a three-competition WC event and five full days for a two-competition WC event, according to the numbers of Biathletes set by the IBU EB. Selection of the best Biathletes for the current competition season, up to the end of December, will be from the top rankings of the previous year's World Cup Total Score. For the part of the season beginning on 1 January, the selection will be from the top rankings in the World Cup Total Score as of the end of December. For the part of the season beginning on 1 February, the selection will be from the top rankings in the World Cup Total Score as of the end of January and will continue on that basis for the remainder of the season.

15.2 WC ANNUAL SCHEDULING

15.2.1 Number of WC per Season

The number of events to be held shall be determined by the IBU EB based on the recommendation by the TC.

15.2.2 WC Annual Calendar

WC events shall be held prior to and after the annual WCH or the OWG. They are to be held in the time-frame set by the IBU EB.

15.3 BIDS TO HOST AN EVENT AND APPOINTMENT OF HOSTS

15.3.1 Authority to Appoint

Hosts of WC events shall be appointed by the IBU EB, based on a recommendation by the IBU TC.

15.3.2 Applications to Host WC Events

Applications for hosting WC events must be submitted by the applying NFs to the IBU Headquarters before the deadline established by the IBU EB. An IBU A license is required to apply. Applications must be submitted to the IBU Headquarters using the official IBU application form and must be signed by the President or SG of the NF.

15.3.2.1 A NF may apply to organize one or more WC events during a competition season. Normally a NF may organize only one WC event per season.

15.3.3 The IBU Event Hosting Declaration

The hosting NF must sign the IBU Event Hosting Declaration, thereby testifying that it accepts and will fulfill, in the required time, the tasks, measures and duties stipulated in the Declaration.

15.4 WC PROGRAM

The program for a WC event will be established by the IBU EB in consultation with the event host, the broadcasting company with which the IBU has entered a contractual agreement for TV distribution and the TC, as soon as possible.

15.5 INVITATIONS

Invitations to WC events must be sent by the OC to all IBU NFs and the IBU Headquarters not later than three months before the start of the event. The invitation may be sent electronically by email or posting on a website with notification by e-mail.

15.6 PARTICIPATION

15.6.1 Registration and Entry Quotas

Based on the previous year's Nations Cup Score final standings, NFs may participate with the following numbers of male and female competitors respectively at WC events:

Individual and Sprint Competitions

Basic quota based on placings in the previous year's Nations Cup Score:

1 – 22	3 competitors
23 – up	2 competitors

Additions and Maximums for Individual and Sprint Competitions

Additionally, NFs may register and enter the number of competitors equivalent to their previous year's top 50 biathletes in the World Cup Total placings, with the combination of the basic quota and additions not exceeding the following:

NF Cup Placing	Enter	Register
1 – 4	7	8
5 – 8	6	7
9 – 12	5	6
13 – up	4	5

15.6.2 Additional Start Rights at WC on the basis of the CC Total Score

For the last two WC events of each season, there shall be the opportunity to enter additional competitors based on the CC Total Score, if there are a minimum of four events included in the circuit with at least two competitions each – not including Relay, as below:

Asia

Maximum of one competitor of each gender per NF, from the top three ranking;

Europe

Top 10 men and top 10 women competitors, maximum two of each gender per NF;

North America

One male and female competitor per NF as decided by US Biathlon and Biathlon Canada respectively;

South America

Top man and top woman.

Rule 1.4.4 shall not be applicable for additional starts. The deadline shall be set by the IBU EB upon recommendation of the TC.

15.6.3 Pursuit Competitions

For the Pursuit competition, the top 60 competitors from the qualifying competition shall be entitled to start.

15.6.4 Mass Start Competitions

The Mass Start competition entries shall consist of the top 30 competitors in the current WC Total Score list. If competitors are missing, filling in will be done from the current WC Total Score list in rank order. Start numbers shall be assigned based on the list standings – with the top ranking NF receiving number 1, the second number 2, and so on.

15.6.5 Relay Competitions

The best 30 nations may enter Relay teams for Men and Women respectively, based on the previous season's Nations Cup Score.

15.6.6 Team Staff

NFs shall be allowed to register team staff according to the number of competitors they registered. If this number is 4 or less, they shall be allowed to register a maximum of 4 team staff members. Starting from 5 competitors the maximum number of team staff that may be registered shall be equal to the number of competitors registered by the respective NF. If the OC is able to accept more than this number, the number must be stated in the invitation along with the conditions for the extra staff.

15.6.7 NFs Not Registered in Time

NFs that have not registered their team by name by the official deadline may participate if the OC accepts the registration and if it is approved by the TD.

15.7 WORLD CUP LEADER START NUMBERS AND FLOWER CEREMONY

15.7.1 General

The competitors, both Men and Women, who are the best ranked in the current World Cup Score in the Individual, Sprint, Pursuit and Mass Start competitions, and in the WC Total Score must wear during the competition a "World Cup Leader" start number.

15.7.2 World Cup Leader Start Numbers

The WC leader start numbers shall have the competitors' number according to the start list and be colored as follows:

- WC Total Score leaders – yellow;
- Each Individual, Sprint, Pursuit, Mass Start leader – red;
- WC Total Score leaders who are at the same time best ranked in the respective competition type – yellow/red combined.

Numbers shall be printed on the start numbers. Any advertising on the WC leader start numbers shall be totally under IBU jurisdiction.

15.7.3 Provision of Leader Start Numbers

The World Cup leader start numbers shall be provided by the IBU and will be brought to WC events as organized by the IBU.

15.7.4 Flower Ceremony

The flower ceremony is the presentation of the top 8 competitors and top 6 Relay teams immediately after the end of the competition. The competitors shall appear wearing their competition start numbers and may have with them their competition materials/equipment.

15.8 WORLD CUP SCORING SYSTEM**15.8.1 General**

A scoring system will be used to reflect the competition performance of competitors, Relay teams and NFs throughout each WC competition season. Those competitors who have attained the highest final scores of the season shall be the winners.

15.8.1.1 Types of Scores

The following types of scores will be used.

- a. World Cup Total Score;
- b. World Cup Individual Score;
- c. World Cup Sprint Score;
- d. World Cup Pursuit Score;
- e. World Cup Mass Start Score;
- f. World Cup Relay Score;
- g. Nations Cup Score.

15.8.2 Awarding of Points

There will be two kinds of points awarded at WC and WCH, or OWG, competitions: World Cup points and Nations Cup points. They will be awarded as follows:

15.8.2.1 World Cup Individual, Sprint, Pursuit, Mass Start and Relay Points

At each WC, WCH or OWG Individual, Sprint, Pursuit, Mass Start and Relay competition, a first place shall give the competitor 50 World Cup points, a second place 46 points, a third place 43 points, a fourth place 40 points, a fifth place 37 points, a sixth place 34 points, then further decreasing by two points down to 15th place (16 points), then further decreasing by one point down to 30th place, which shall give 1 point.

15.8.2.2 Nations Cup Points

At each WC, WCH or OWG Individual and Sprint competition, a first place shall give the competitor 150 Nations Cup points, the second

146 points, the third 143 points, the fourth 140 points, the fifth 137 points, the sixth 134 points and then decreasing by two points down to 15th place (116 points), then further decreasing by one point per place to 1 point.

Relay Nations Cup points shall be awarded at each OWG, WCH, and WC according to the chart shown below:

1.	2.	3.	4.	5.	6.	7.	8.	9.	10.
450	420	390	360	330	310	290	270	250	230

11.	12.	13.	14.	15.	16.	17.	18.	19.	20.
220	210	200	190	180	170	160	150	140	130

21.	22.	23.	24.	25.	26.	27.	28.	29.	30.
120	110	100	90	80	70	60	50	40	30

15.8.3 Criteria

The number of competitions to be scored in each type of competition, the Total Score and the Nations Cup score will be set annually by the EB upon recommendation of the TC and will be published in the IBU Biathlon Calendar.

15.8.3.1 WC Total, Individual, Sprint, Pursuit, Mass Start and Relay Scores

Scoring will be based on the Individual, Sprint, Pursuit, Mass Start and Relay competitions of the WC events and the WCH, or OWG, of that season.

15.8.3.2 Nations Cup Score

Scoring of the Nations Cup shall be based on all of the WC and WCH, or OWG, Individual, Sprint, and Relay competitions of that season.

15.8.4 Calculation**15.8.4.1 World Cup Total Score**

For all competitors, the World Cup Total Score will be based on the Individual, Sprint, Pursuit and Mass Start competitions. The scores from the set numbers of competitions will be added together and the sum will be the WC Total Score.

15.8.4.2 World Cup Individual, Sprint, Pursuit and Mass Start score

The WC score of each of the types of the competitions will be calculated the same way by adding together the scores of the set number of competitions for each type.

15.8.4.3 Nations Cup Score

- a) The NFs' best three competitors' Nations Cup points in Individual and Sprint competitions shall be added together and that sum shall become the NF's Nations Cup Score for that competition. The Relay Nations Cup points shall be added to those from the Individual and Sprint; the cumulative sum shall become the respective NF's current ranking.
- b) After the WC Final, based on numbers set by the IBU EB, the best Individual, best Sprint and the best Relay competition Nations Cup Scores for each NF shall be counted from all of the Individual, Sprint, and Relay competitions of that season and will be added together. The sum will become the NF's Nations Cup Score.

15.8.5 Breaking of Ties in Standings

If there is an equal number of points in any standings during or at the end of the season, the best placed competitor or NF shall be the one who won more first places, and if there is still a tie, who won the most second places, etc. If, after following this procedure, the tie cannot be broken, a tie will be declared.

15.8.6 World Cup Score**15.8.6.1 Interim Standings**

After each WC and WCH, or OWG competition, the OC of the event must compile and distribute a World Cup interim standing list based on the results of that and the preceding competitions.

15.8.6.2 Final Score

The OC of the World Cup Final must compile and distribute lists for the final Score of all the World Cup and Nations Cup Scores to all NFs that took part in any WC event in that season.

15.9 AWARDS**15.9.1 General**

World Cup trophies will be awarded at the end of the competition season, based on the World Cup Score final standings. In order to

avoid extremely lengthy ceremonies, the trophies will be awarded by the IBU Representative in a dignified ceremony after the last competition of each competition type of a season.

15.9.2 Award Categories

The World Cup trophies shall be awarded to:

- a. the Man and Woman placed first in the World Cup Total Score;
- b. the Man and Woman placed first in the World Cup Individual Score;
- c. the Man and Woman placed first in the World Cup Sprint Score;
- d. the Man and Woman placed first in the World Cup Pursuit Score;
- e. the Man and Woman placed first in the World Cup Mass Start Score;
- f. the NFs placed first in the Men's and Women's World Cup Relay Scores;
- g. the NFs placed first in the Men's and Women's World Cup Nations Score.

15.9.3 Right to Retain Trophies

World Cup trophies may be retained as follows:

- a. The World Cup trophies awarded for the World Cup Total, Individual, Sprint, Pursuit and Mass Start Scores shall become the property of the winners.
- b. The World Cup trophies awarded for the World Cup Relay Score shall become the property of that NF.
- c. The Cup for the World Cup Nations Score is a perpetual challenge cup that will be retained by the IBU. Miniature cups, for retention by the winning NFs, will be awarded every year.

15.9.4 Provision of Trophies

The World Cup trophies and certificates shall be provided by and at the expense of the IBU.

15.9.5 World Cup and Nations Cup Certificates

The IBU will present a certificate to the 10 best placed competitors and NFs according to the World Cup Total Score and Nations Cup. In each type of competition the IBU will present a certificate to the top placed competitor at the end of a competition season. The presentations will take place during the WC Final at a suitable occasion.

15.9.6 Other Prizes

The OC and other bodies may present other prizes.

15.9.7 Prize Money

Prize money shall be permitted in amounts as directed by the IBU EB.

16. ENTRY INTO FORCE

The IBU Event and Competition Rules were adopted by the 1998 Congress and amended by the 2000, 2002, 2004 and 2006 Congresses. The last amended version entered into force on 3 September 2006.



IBU

**ANNEXES
TO THE IBU EVENT
AND
COMPETITION RULES**

LIST OF CONTENTS

ANNEX A	MATERIAL CATALOGUE
ANNEX B	DUTIES OF THE COMPETITION JURY, TECHNICAL DELEGATES AND INTERNATIONAL REFEREES
ANNEX C	TRAINING AND LICENSING OF TECHNICAL DELEGATES AND INTERNATIONAL REFEREES
ANNEX D	RULES FOR CONTINENTAL CHAMPIONSHIPS
ANNEX E	RULES FOR CONTINENTAL CUP EVENTS
ANNEX F	RULES FOR SUMMER BIATHLON

ANNEX A MATERIAL CATALOGUE

ANNEX A

TABLE OF CONTENTS

1.	GENERAL	
1.1	Purpose	2
1.2	Definition	2
1.3	General Prohibitions	2
2.	NEW MATERIALS	
2.1	Definition	3
2.2	Approval process	3
3.	MATERIAL SPECIFICATIONS	
3.1	Competition Equipment	4
3.2	Organization Equipment	8
4.	ADVERTISING	
4.1	Advertising Rules	13
4.2	Commercial Markings on Equipment	13
4.3	Measurement of Advertising Surfaces	13
4.4	Preliminary Examination of Advertising	14
5.	INSPECTION PROCEDURES	
5.1	General	15
5.2	Competition Equipment	15
5.3	Organization Equipment	15
5.4	Inspection Instruments, Tools and Materials	16
TABLE 1	Biathlon Rifle Diagram	17
TABLE 2	Standard Dimensions for Biathlon Targets	18
TABLE 3	Example of a Wind flag	18

1. GENERAL

1.1 PURPOSE

The purpose of the IBU Material Catalogue is to regulate all aspects of materials relating to Biathlon competitions. It is based on the binding nature of the IBU Event and Competition Rules and is part of those Rules. The Material Catalogue provides the definitions, current specifications and requirements of all competition-related material, the approval process for the admission of new materials and the inspection procedures for enforcing the material regulations. In essence, the Material Catalogue safe-guards:

- a. the principle of fairness and equal opportunity for all competitors;
- b. the safety and health of all persons associated with Biathlon competitions;
- c. the preservation of the nature and traditions of the sport of Biathlon.

1.2 DEFINITION

The term material is sub-divided into two major categories: Competition Equipment and Organization Equipment.

1.2.1 Competition Equipment

Competition equipment refers to all items that a competitor wears or carries for a competition and Official or Unofficial training during an event. Competition equipment includes e.g. skis, poles, bindings, boots, rifle, ammunition and magazines, clothing; and accessory equipment such as gloves, goggles and earmuffs, rifle bags and ski clips.

1.2.2 Organization Equipment

Organization equipment consists of all the other materials that are required to conduct a Biathlon competition or training during an event, that are not worn or carried by the competitor. Examples of organization equipment are: targets, timing equipment, mats, relay cups, wind flags, signage and equipment measuring devices, etc.

1.3 GENERAL PROHIBITIONS

In principle all materials shall be prohibited that:

- a. affect the natural movement of feet and arms during push off action or those that enhance it (such as spring devices or other mechanisms in skis, poles, bindings or boots);
- b. make use of sources of energy not originating from the competitor, such as artificial heating devices, chemical energy suppliers, electrical batteries, mechanical aids, etc.;

- c. affect the external conditions for the competition to the detriment of other competitors, such as changing the track or snow conditions;
- d. increase the risk factor for injury of competitors and other persons who are authorized to be present on the competition facility, when used normally.

2. NEW MATERIALS

2.1 DEFINITION

New material is defined as any competition equipment or organization equipment that has not been approved or rejected by the IBU TC. Any new material must be submitted to the IBU TC Material Sub-Committee for approval before it can be used in an IBU event or competition.

2.2 APPROVAL PROCESS

2.2.1 Procedure

Any new developments in materials produced by the industry or the NFs for the following season must be submitted to the IBU no later than 1 May of the year in which the season begins. The submission must be accompanied by appropriate information material such as drawings, descriptions or test results. Prototypes may be submitted as well. New developments that are in accordance with the regulations will be immediately approved by the IBU TC Material Sub-Committee.

2.2.2 Provisional Approval

In rare cases a provisional approval may be granted for a year, following which a definitive decision must be made in the subsequent season.

2.2.3 Standard Products

New designs of competition clothing, bindings, boots, rifle slings, headgear and gloves do not have to be presented to the IBU TC Material Sub-Committee, provided that it is clear that the new products meet IBU regulations. If the materials do not meet regulations they can be banned on short notice.

2.2.4 Availability

Any new materials must be accessible to all NFs and competitors in the following season.

3. MATERIAL SPECIFICATIONS

3.1 COMPETITION EQUIPMENT

3.1.1 Competition Skis

Changes to these regulations will be published in the IBU Biathlon Calendar as required.

3.1.1.1 Ski Length

Minimum length of skis shall be the height of competitor minus 4 cm; maximum length: no limit. If the competitor is so tall that commercially produced skis are too short for him according to this rule, the TD may authorize an exemption so that the competitor may use the longest commercially available skis of any usual brand.

3.1.1.2 Ski Width

The ski waist, measured under the binding, can have a minimum width of 40 mm; maximum: no limit.

3.1.1.3 Ski Tip Section

Minimum width of the ski tip area shall be 30 mm.

3.1.1.4 Ski Tail Section

When the unweighted ski is placed on a flat surface, the height of the ski tail from the surface must not exceed 3 cm.

3.1.1.5 Weight

The total weight of a pair of skis must be at least 750 grams, without bindings. There shall be no restrictions on the distribution of weight.

3.1.1.6 Construction

3.1.1.6.1 Type of Construction

No limitations.

3.1.1.6.2 Shaping

Both skis must have the same type of construction, so that there is no difference between the left and the right ski. There shall be no restrictions on the types of lamination construction used. There shall be no limitations on rigidity in any dimension.

3.1.1.6.3 Gliding Surface

The entire length of the running surface can either be smooth or slightly grooved in the longitudinal direction. Except for the guiding

grooves, the entire length and width of the running surface must be flat. Engraved or impressed climbing aids such as scales or steps shall be permitted. Devices that are activated by any energy other than the competitor's own muscular power shall not be permitted.

3.1.1.6.4 Top Surface

No limitations.

3.1.1.6.5 Edges

The side walls may not be angled as they extend upwards so that the ski base becomes narrower than the upper surface (wedge form not allowed).

3.1.1.7 Stress Properties

No limitations.

3.1.2 Ski Bindings

There are no restrictions on the type of material used or its make.

3.1.3 Competition Ski Boots

There shall be no restrictions on the type of material used or their construction.

3.1.4 Competition Ski Poles

3.1.4.1 Specifications

- a. The maximum length of the poles must not be longer than the competitor's body height, measured by placing the pole tip on the ski in front of the binding;
- b. The pole must have a fixed length: the shaft must not be telescoping or of variable length;
- c. The pole must not have any energy source to improve push, such as springs or other mechanical devices;
- d. There shall be no upper or lower weight limit for poles;
- e. The poles may be asymmetrical: there can be a distinct right and left hand pole;
- f. The pole must not cause changes to the competition conditions such as changes to track or snow conditions;
- g. The hand grip must be permanently fastened to the shaft. There are no restrictions concerning its geometry, construction or material;
- h. The strap must be connected to the handgrip or the shaft but may be detachable. It can be adjustable both in length and width. There are no restrictions on materials;

- i. There are no limitations on the shape or material of the shaft, or on the mass distribution;
- j. Exchangeable baskets with different geometric features and materials to match different snow characteristics shall be allowed;
- k. The tip may be connected at any angle to the shaft. One or more tips shall be allowed. There shall be no restrictions on materials.

3.1.5 Clothing

The following regulations shall apply to competitors' apparel:

- a. Advertising on the competition clothing must be in accordance with the current IBU regulations;
- b. Padding shall only be allowed on the inside of the racing suit. The total thickness of the padding, cloth and lining of the competition garment may not exceed 6 mm when measured in an unpressed state, except on the back of the suit, where the rifle is carried. The back area shall not be subject to any restriction on padding;
- c. On the outside of the sports clothing no adhesive materials, such as Velcro or tape, wax, resin, glue or any additional stitching (with the exception of the stitching to fasten the padding) may be used. However, non-slip material may be used;
- d. A special device for preventing the shooting sling from slipping down shall be allowed on the sleeve of the upper arm.

3.1.6 Rifles

3.1.6.1 General

The rifles may not be of automatic or semi-automatic design. Loading or unloading may be executed only by the competitor's muscle force.

3.1.6.2 Parts of a Biathlon Rifle

A diagram of a Biathlon rifle with names of parts is provided in Table 1.

3.1.6.3 Approved Types of Actions

The types of authorized rifle actions are as follows:

- a. the common bolt system;
- b. pistol grip cocking;
- c. straight pull action;
- d. straight pull action with ball-bearing locking.

3.1.6.4 Specifications

Rifles used in competitions must meet the following specifications:

- a. The distance between the center-line of the barrel and the lower edge of the forestock, including magazine and trigger guard, must not exceed 120 mm;
- b. The thickness of the cheek piece, measured from the vertical of the center-line of the barrel, must not exceed 40 mm;
- c. A folding stock is not permitted;
- d. The sight system may not have any optical device and may not have a magnifying effect. The insertion of optical lenses into the eye for this purpose is also prohibited;
- e. The caliber of the barrel must be 5.6 mm (.22 in. long rifle);
- f. The trigger resistance must be a minimum of 0.5 kg;
- g. The trigger must be surrounded by a rigid, closed trigger guard;
- h. The rifle may have a sling and must have a carrying harness. The width of the sling and cuff must not exceed 40 mm;
- i. Including all accessories — except magazines and ammunition — the minimum weight of the rifle must not be less than 3.5 kg;
- j. The magazines must not permit the insertion of more than 5 rounds. For the Relay competition, three spare rounds may be carried in a magazine installed for that purpose, or in a special quick release device. However, a spare round may not be carried in the chamber. The magazines may be carried in the forestock or the butt.
- k. The advertising attached to the rifle must be in conformity with current IBU regulations;
- l. On both sides of the forestock, a smooth — meaning flat or nearly flat —, rectangular IBU marking surface shall be kept free of other markings and reserve ammunition, namely 15 cm in front of the trigger or the bolt handle or the front end of the trigger guard (the competitor may choose), over the entire width of the stock and at least 4 cm high. Alternatively, the bolt handle or the trigger guard may extend into this area, however, only so much that the IBU rifle control sticker is not covered up or cut off.

3.1.7 Ammunition

3.1.7.1 Required Characteristics

Only international standard .22 in. (5.6 mm) long rifle rim fire ammunition may be used. The bullets must be made of a uniform substance, lead or a similar soft material such as a lead alloy.

3.1.7.2 Muzzle Velocity

The muzzle velocity must not exceed 380 m/s, measured 1 m after leaving the muzzle.

3.1.7.3 Hit Impulse

The impact of the bullet, fired from a distance of 50 m at a relatively stiff steel plate, must not exceed 0.9 Ns (=0.09 kps) with a maximum impact tolerance of 0.099 Ns.

3.1.7.4 Hit Impulse Tolerance and Testing

The maximum permitted tolerance in hit impulse value of the tested ammunition shall be 11 %, that is, maximum hit impulse shall be 1.0 Ns (=0.1 kps). Admissibility of ammunition can be verified by shooting at a test target with variable release impulse. This target must be adjusted in such manner that no release occurs at a hit impulse at 1.0 Ns, but definitely records a hit impulse at 1.1 Ns. Ammunition shall become authorized for use if no release is recorded after 5 shots have been fired from a distance of 10 m. Testing of ammunition must be done with the competitor's own rifle or an identical one. Ammunition testing may be ordered by the Competition Jury during an event.

3.1.8 Rifle Bag

The rifle bag must provide a window of minimum 15 x 15 cm that allows a clear view of the rifle bolt.

3.2 ORGANIZATION EQUIPMENT**3.2.1 Target Systems****3.2.1.1 Uses of Targets**

The numbers and types of targets authorized for use in various competitions are detailed in the IBU Event and Competition Rules. Targets must be situated, set up, numbered and maintained as detailed in the IBU Event and Competition Rules.

3.2.1.2 Types of Targets

There are two main types of targets used for Biathlon training and competitions – metal and paper.

3.2.1.3 Targets – OWG, WCH and WC

At OWG, WCH and WC competitions only electro-mechanical and electronic target systems that are in accordance with the current IBU Material Catalogue shall be used.

3.2.1.4 Targets – Y/JWCH, CCH and CC

For Y/JWCH, CCH and CC competitions, mechanical, manually operated targets will be permitted, but the use of electro-mechanical and electronic targets is to be encouraged. The ropes for manually operated targets should be placed through tubes under the shooting ramp to the rear of the ramp so that the targets can be operated without interference to shooters.

3.2.1.5 Metal Target Operating Systems

Metal targets are produced in mechanical and electro-mechanical variations. They operate as follows:

a. Mechanical Target Operating Systems

In a mechanical target the hit of a bullet is indicated by the physical force of the bullet impact knocking down the target and replacing it with a white indicator disc. As well, mechanical targets can be manually reset after a shooting bout by pulling a rope to bring the fallen target plates back into position. Changing between standing and prone configurations is done manually with a rope for mechanical targets;

b. Electro-Mechanical and Electronic Target Operating Systems

In an electro-mechanical or electronic system, the resetting of targets and changing configurations is done by remote control with electrically powered servo-motors. Hits in electro-mechanical or electronic systems are normally recorded electronically through a magnetic, motion or impact sensor in the target. Visual hit indication normally occurs with a mechanically or electronically activated white indicator disc.

3.2.1.6 Metal Target Description

The target must consist of a white target face plate with 5 target apertures, behind which are 5 independently operating knock down, falling plate or electronic sensor plate scoring targets. The scoring plates must be black. A hit must be indicated by the black target circle being replaced by a white indicator disc.

3.2.1.7 Paper Target Description

Paper targets must be identical to the metal targets in size and appearance. The paper background must be white in color and may not be reflective. The five circular targets must be black.

3.2.1.8 Target Sizes and Aperture Positions

Table 2 details all the required dimensions and the positioning of the

target circles for both metal and paper targets. The diameters of the black circles for the aiming and the scoring areas, for both metal and paper are as follows:

Standing	- aiming	115 mm	
	- scoring	115 mm	(dotted line at 110 mm on paper targets)
Prone	- aiming	115 mm	
	- scoring	45 mm	(dotted line at 40 mm on paper targets).

3.2.1.9 Functional Requirements for Metal Targets

The target system must meet the following requirements:

- Reliable functioning under all types of weather conditions in which competitions are carried out;
- The release of the hit register at a standard hit impulse (releasing impulse) that has been determined by the IBU TC Material Sub-Committee, to ensure that the same releasing impulse is functional for all targets used during a competition.

3.2.1.10 Tolerances and Shape Requirements

Size for target openings must be:

Diameter 115 mm, +/- 0.3 mm for standing position;

Diameter 45 mm, +/- 0.3 mm for prone position.

The target apertures used for shooting in the standing and prone positions must be concentric. Permissible tolerance shall be 0.3 mm. The aperture rim must be well defined and devoid of deformations. Centering of the prone target aperture must be within a tolerance of +/- 0.5 mm.

3.2.1.11 Deformations

Continuous use of a target system can result in deformations of the flat surface.

Such deformations must not deviate more than 1 mm from the remaining surface of the target. The depth of the deformation must be measured relative to the edge of the surface of the 115 mm diameter target.

3.2.1.12 Material and Hardness

Metal targets must be made of steel with a hardness of at least 350 HB, with a hit plate with a minimum of 480 HB.

3.2.1.13 Release Impulse

The release of the hit impulse should occur when hit by a bisected bullet at a release impulse of at least 0.45 Ns. A release tolerance of +/- 33.33 % shall be permitted. That means that all target systems must be adjusted in such a manner that it is independent of where the bullet hits the target.

A release impulse of less than 0.3 Ns will not be recorded as a hit; a release impulse greater than 0.6 Ns will definitely be recorded.

3.2.1.14 Special Requirements for Electronic Target Systems

In addition to the standard requirements for Biathlon targets, electronic systems must comply with the following:

a. Data Feed Distribution

The system must be able to distribute data to multiple operation points such as timing, data processing and TV (including graphics) production;

b. Interface Hardware

All data flow to other than system internal requirements must be by use of RS-232 interface. No buffering or handshake controls are necessary;

c. Communication Protocol

In order to process and log the data feed with standard PC equipment, a simple ASCII coded protocol must be used. The following information must be transmitted:

- competitor arrival at shooting lane (start of shooting);
- assignment of start number to shooting lane, including A to D indicators for Relay competitions;
- missed shot(s);
- target hits (including target plate numbers 1 to 5);
- end of shooting bout (important data such as shooting lane, start number, total misses, number of spare rounds used in Relay competitions, and shooting time should be in this feed);

d. Transmission Delay

The maximum delay, from registering of a target hit or missed by the sensor system of the targets, to the complete transmission via the data output line must not exceed 200 ms. This value must also be maintained during heavy shooting on the range, such as in the Pursuit and Mass Start competitions;

e. Backup Systems

To guarantee reliable data feed during major international events,

the target system must have two completely separate processing systems, and therefore, must provide two data feeds to the main and backup timing, data processing and TV graphics systems.

3.2.1.15 Approval of Targets

All target systems that are to be used during IBU competitions will require approval by the IBU TC Material Sub-Committee. Authorization of a target system will be granted to a manufacturer who submits a prototype to the IBU, which the IBU then finds acceptable according to these regulations. Approval can be withdrawn if technical flaws occur, or when a particular type of target system becomes technically outdated.

3.2.1.16 Targets Currently Authorized by the IBU

At present, the following target systems are approved for use:

- a. Mechanical Systems
 - Kurvinen – FIN
 - Devon Model BT-500 – USA
 - HORA 1000 – GER
 - VingMek – NOR;
- b. Electronic/electro-mechanical Systems
 - Kurvinen (KES 2002) – FIN
- c. Electronic Systems
 - HoRa 2000 E – GER.

3.2.2 Wind flags

The wind flags for the shooting range must be of a highly visible color, 10 x 40 cm in size and must be made from thin artificial silk or natural silk. Flags may not weigh more than 5 grams. Their construction must allow for easy 360 degree rotation, pivoting at a right angle to the flag post. A diagram of wind flag construction is shown in Table 3 of this Annex.

3.2.3 Relay Cups

A relay cup is a container on a stand for holding spare rounds, placed 1 m above the ground. The containers must have rounded bottoms and must facilitate the easy picking-up of the spare rounds.

3.2.4 Start Numbers

3.2.4.1 Sizes

Sizes of start numbers shall be as follows:

- a. Front and back numbers:
 - outlined figures or block figures - height at least 12 cm, width (of each line in a figure) at least 1.5 cm for outlined figures and 2 cm for block figures;
- b. Side numbers on the start number:
 - height at least 6 cm, width at least 1.2 cm. The bottom edge of the figures on the sides must be spaced 8.5 cm from the bottom edge of the start number;
- c. Leg numbers: 12 cm high and 2 cm wide.

3.2.4.2 Cloth/Material

Pullover (vest) start numbers must be made of smooth cloth, 100% polyester interlock or 100% polyester-warp knitting. The start numbers must be tailored to the needs of the competitors: they may not impede movements of the shoulder joints.

3.2.5 Timing Equipment

For OWG, WCH, Y/JWCH and WC competitions, computer supported electronic timing equipment must be used. The equipment must be compatible for electronic interface with the target system in use and must have electric or electronic sensors at the start and finish. Additionally, the equipment system must be able to receive and process manually or automatically activated intermediate time signals. For manual timing, good quality professional stop watches or manually activated electrical timing devices must be used.

4. ADVERTISING

4.1 ADVERTISING RULES

The IBU advertising regulations (IBU Rules for Advertising) shall apply to the WCH, Y/JWCH, WC, CCH and CC events and competitions.

4.2 COMMERCIAL MARKINGS ON EQUIPMENT

Technical specifications of the size, the form and the number of commercial markings will be decided by the EB and will be published in the IBU Biathlon Calendar or as a separate document.

4.3 MEASUREMENT OF ADVERTISING SURFACES

4.3.1 General

Advertising occurs in two dimensions within a shape defined by its

text, line boundary or color boundary. All advertising will occur in square, rectangle, triangle, circle, polygon or irregular shapes. The size of the surface area that the text or the area within the boundary occupies must be determined by measuring in order to approve or reject the advertisement according to the sizes stipulated in the foregoing regulations.

4.3.2 Measuring Procedures

The size of the commercial marking is the surface area within a line that follows the actual outline of the full marking. If the marking is contained within an area of different color, the total surface area having a different color from the competition clothing is to be measured.

4.3.3 Text or Letters

If the text is within a line or color boundary, the applicable shape formula will be used. If the text or letters stand alone on the general garment background, the outline of the furthest extensions of the letters will be traced and the appropriate shape formula then applied to the outline thus created.

4.3.4 Measurement of Geometric Shapes

The surface area of a square, rectangle, triangle, circle or polygon will be determined by the standard geometric formula. If there is doubt about a polygon being a polygon, it is to be measured as irregular.

4.3.5 Irregular Shapes

If the appropriate equipment is available, a computer scanner may be used to determine the surface area. If the computer devices are not available, a string must be used to trace the outline to determine the number of square cm in the area.

4.4 PRELIMINARY EXAMINATION OF ADVERTISING

In cases of doubt about the size of advertising, NFs are requested to send an actual size fax or photocopy to the IBU SG, as early as possible before the start of the competition season, for a determination of its size. If questions exist about certain advertisements after the start of the competition season, NFs will be requested to present the items at latest at the preliminary examination of materials/equipment or clothing for the respective event.

5. INSPECTION PROCEDURES

5.1 GENERAL

Inspections must be conducted on competition and organization equipment to ensure that all material is in accordance with all IBU regulations.

5.2 COMPETITION EQUIPMENT

The inspections that must be carried out on competition equipment are detailed in the IBU Event and Competition Rules. Inspections will be conducted primarily by the organizing staff appointed for that purpose and by the IR Material Inspection responsible for an event. Competition Juries and TDs shall be responsible for the effective and correct implementation and enforcement of material inspections.

5.3 ORGANIZATION EQUIPMENT

TDs and IRs shall be responsible to ensure that organization equipment used within their area of responsibility is functional and conforms with all IBU regulations.

5.3.1 Specific Checks

5.3.1.1 Targets

- a. placement and levels;
- b. functioning, paint and maintenance;
- c. deformation of face and target plates;
- d. condition of moving parts;
- e. position of wires and cables;
- f. diameter measurement of target apertures;
- g. centering of prone apertures;
- h. strike test of target release impulse;
- i. routing of reset ropes in mechanical systems;
- j. backup system for those systems that require electrical power.

5.3.1.2 Timing Systems

- a. principle of operation;
- b. functioning and maintenance;
- c. backup and redundant systems;
- d. power sources;
- e. placement of sensors;
- f. computer capabilities, including speed of producing printed results;
- g. interface with electronic target systems.

5.3.1.3 Computers for Draw of Start Numbers

- a. functioning and maintenance;
- b. printers;
- c. display device, projector;
- d. software program – validity, possibility of manipulation;
- e. backup and spares;
- f. total system interfaces and placement;
- g. speed of producing start lists.

5.3.1.4 Other Organizational Equipment (in IBU Event and Competition Rules)

- a. wind flags – placement, operation, specifications;
- b. relay cups – placement, specifications;
- c. shooting mats – placement, specifications;
- d. rifle racks – construction, placement, markings;
- e. lane markers – placement, color, no interference with shooting;
- f. numbering and signage – placement, sizes, colors.

5.4 INSPECTION INSTRUMENTS, TOOLS AND MATERIALS

The following is a list of devices required for material and other checks that should be available to the responsible officials:

- a. measuring tapes (50 or 100 m) – for various measurements: range, penalty loop;
- b. water/bubble levels – for checking level of targets;
- c. radar chronograph – for checking ammunition velocity;
- d. strike tester – for target plates;
- e. centering template – for prone target apertures;
- f. weigh scale – for weighing rifles and skis;
- g. templates – for measuring rifle dimensions;
- h. calipers, rulers – for measuring the dimensions of rifles, skis, advertising;
- i. trigger weights – for measuring trigger resistance;
- j. stickers, paint – for applying inspection markings.

TABLE 1 Biathlon Rifle Diagram

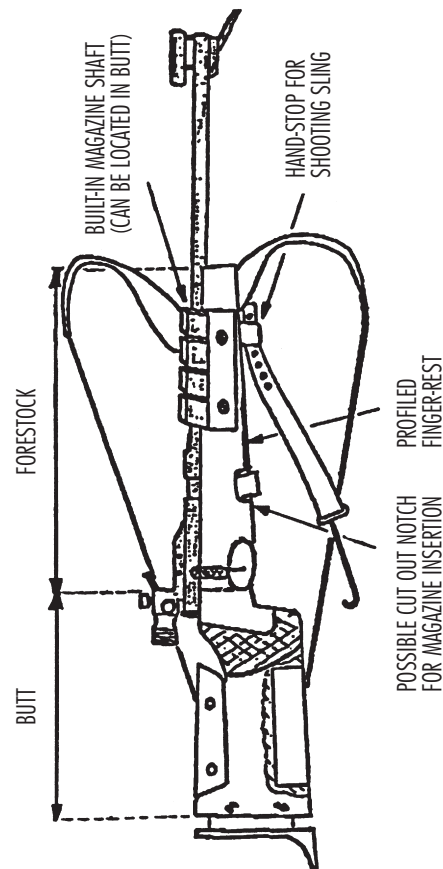

TABLE 2 Standard Dimensions for Biathlon Targets

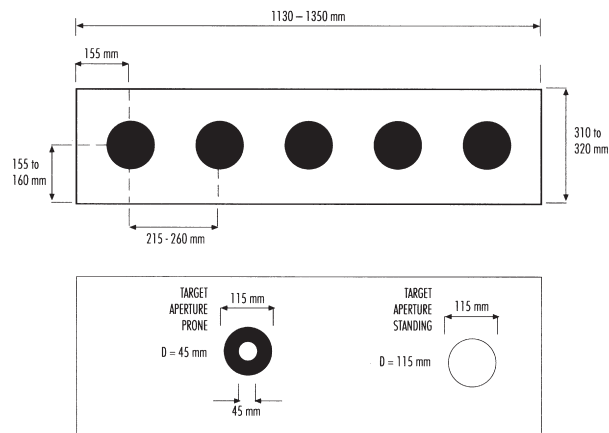
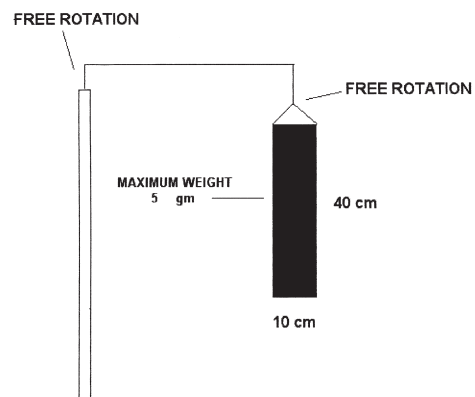

TABLE 3 Example of a Windflag



ANNEX B DUTIES OF THE COMPETITION JURY, TECHNICAL DELEGATES AND INTERNATIONAL REFEREES

ANNEX B

TABLE OF CONTENTS

1.	COMPETITION JURY	
1.1	General	2
1.2	Substitute Chairman	2
1.3	Competition Jury Meetings	2
1.4	Tasks of the Competition Jury	2
2.	TECHNICAL DELEGATES	
2.1	General	4
2.2	Principles of the TD Function	4
2.3	Contact with OCs and Site Visits	4
2.4	TD Tasks at Events	6
3.	INTERNATIONAL REFEREES	
3.1	General	9
3.2	IR Tasks at Events	10
3.3	IR Authority, Responsibilities and Organizational Relationships	11

1. COMPETITION JURY

1.1 GENERAL

The powers, election, composition and various procedures of Competition Jury operations are detailed in the IBU Event and Competition Rules. This Annex provides additional procedural directives and the specific tasks of the Competition Jury.

1.2 SUBSTITUTE CHAIRMAN

If the Competition Jury Chairman is absent, the remaining Jury members shall appoint a replacement from among themselves to chair the meeting.

1.3 COMPETITION JURY MEETINGS

The Competition Jury will meet when so directed by the Competition Jury Chairman. Meetings will normally be held as follows:

- a. immediately after the Team Captains Meeting where it was elected;
- b. approximately one hour before the start of the competition;
- c. at any time during the competition when directed by the Competition Jury Chairman;
- d. immediately before the last finish in the competition, or as soon as possible after the last shooting;
- e. at any other time when a meeting is called by the Competition Jury Chairman.

1.4 TASKS OF THE COMPETITION JURY

The Competition Jury shall have the following tasks:

1.4.1 Prior to the Competition

- a. to check if the competition venue complies with the rules;
- b. to check the eligibility of all competitors registered for the event;
- c. to supervise the draw;
- d. to determine if a competition has to be postponed or annulled due to serious difficulties (such as extremely unfavorable weather conditions — extreme cold, high winds, etc.);
- e. to restrict or prohibit training on the competition venue due to adverse circumstances such as very wet snow or very little snow that could jeopardize the conduct of the competitions;
- f. to decide if, and under which conditions, a late entry may be accepted;

- g. to decide if a competitor properly entered for participation may be replaced by a substitute in the case of force majeure;
- h. to decide on protests concerning eligibility of competitors;
- i. to check if the qualification records of a competitor submitted by a NF permit the competitor's participation in OWG or WCH, or if start must be denied;
- j. to appoint a Competition Jury member to be permanently present on the range during the competition;
- k. to appoint a Competition Jury member to assist at the inspections of the equipment;
- l. to order ammunition checks, if required.

1.4.2 During the Competition

- a. to ensure that the competition is conducted according to the IBU Event and Competition Rules;
- b. to direct the necessary measures if difficulties occur — such as heavy fog or a storm — that seriously endanger the correct and fair conduct of the competition: an extreme option may be to stop the competition;
- c. to decide on the admission of competitors who arrive late at the start due to force majeure.

1.4.3 After the Competition

- a. to oversee the critical process that begins immediately after the last finish, relating to the authorization of the unofficial awards ceremony and the posting of Provisional Results;
- b. to decide on protests;
- c. to impose or reject the penalties reported by the TDs, IRs, Competition Jury members and officials of the Organizing Committee;
- d. to determine necessary time adjustments;
- e. to annul a competition, if necessary;
- f. to order the repeat of a competition, if justified and possible.

1.4.4 Before, During and After the Competition

The Competition Jury must be prepared at all times to decide on all matters that are not covered in the Rules or other IBU regulations.

2. TECHNICAL DELEGATES

2.1 GENERAL

Regulations for the selection, appointment and general duties of TDs are given in the IBU Event and Competition Rules. This Annex provides more specific guidelines for the performance of TD duties. TDs appointed for IBU events must consult both this Annex and the IBU Event and Competition Rules.

2.2 PRINCIPLES OF THE TD FUNCTION

The TD at an IBU event shall have three primary functions:

- a. to represent the IBU in a technical capacity;
- b. to ensure that the event and its competitions are conducted in accordance with the IBU Event and Competition Rules and with other pertinent IBU regulations;
- c. to act as a consultant and advisor to the OC to ensure that the competitions are held as well as possible.

As well, the TD is always the Competition Jury Chairman, an extremely critical position. Additionally, the TD shall function as the leader of the IBU technical group of IRs. The TD must conduct his duties with dignity, competence, caution and objectivity. He must treat competitors, team staff, OCs and IRs with respect and must demand to be treated with the same respect, as the technical representative of IBU, by all persons involved with the event. The TD must stop all attempts by anyone to interfere with his work or to usurp his authority or mandate. In serious cases of interference, the TD must report the circumstances to the IBU SG and to the IBU Race Director. OCs, teams and IRs must follow the directions given in accordance with the IBU regulations by the TD in the preparation and conduct of the event.

2.3 CONTACT WITH OCS AND SITE VISITS

2.3.1 Establishment of Contact

Immediately following the appointment of TDs for events, the IBU SG shall inform the OCs of events for the following season about the TD appointments. Normally the OCs will contact the TD shortly after being advised. If this does not happen, the TD must contact the OC, and inform the SG that he has done so.

2.3.1.1 Continuing Contact and Problem Solution

After initial contact is established, the TD and OC may communicate

as necessary, however, it is advisable that the SG be forwarded copies of all written correspondence. If any problems arise with the OWG or WCH, the SG must be informed immediately.

2.3.2 Inspections and Site Visits

A TD should inspect the site of the event for which he has been appointed in time to direct necessary changes in the facility or plans, and to give timely assistance to the OC. Inspections are to be made as follows:

2.3.2.1 OWG

Normally both TDs should first visit the site for an inspection and meetings shortly after the host of the Games has been appointed. The visit is to be organized in consultation with the SG and the OCs. Further visits will be made as necessary.

2.3.2.2 WCH and Y/JWCH

The TD has to inspect the competition venue not later than eight months prior to the beginning of the event.

2.3.2.3 WC, CCH and CC Events

The inspection must be made not later than four months before the event. If the OWG, WCH, Y/JWCH or a WC event has been held on the site within the previous two competition seasons, it will not be necessary to make an inspection prior to the coming event. However, if major changes have been made or if the OC wishes an inspection, the TD will inspect.

2.3.3 Areas to be inspected

During the inspection the following must be confirmed:

- a. The competition venue must be in accordance with the IBU Event and Competition Rules;
- b. All preparations for the event must be in accordance with the IBU Event and Competition Rules;
- c. The structure of the Organizing Committee must be appropriate and the officials appointed for the event must be properly trained and prepared, and a sufficient number have the required IR license;
- d. Accommodation and food arrangements for teams must meet the requirements, including costs per person for full board;
- e. Transport plans must be functional and distances within the requirements;

- f. Import and export laws for rifles and ammunition must be clear, and what storage arrangements have been made for rifles and ammunition;
- g. Appropriate publicity arrangements must have been made with the press, radio and TV;
- h. Measures for conducting Doping Controls including blood tests must have been arranged;
- i. All required safety precautions must have been implemented.

2.3.4 Inspection Reports

TDs must make a written report of inspections to the IBU SG, the VP for Sport, the IBU Race Director and the Chairman of the Organizing Committee immediately following the inspection. The reports should in particular address unresolved problems and unsatisfactory situations but must also include the information in the following format:

- a. Title name of event, location, date(s) of inspection;
- b. Inspection Party: names and appointments of persons who participated in the inspection;
- c. Inspection Routine: meetings, facility inspections;
- d. Site and Facility Description: general location and character of the site, description of the venue course, stadium, shooting range, etc.;
- e. Organizing Committee: general structure, numbers of appointed officials, relevant training and qualifications;
- f. Hosting Arrangements: accommodation, meals, transport, ceremonies, social events, media, costs;
- g. Problem Areas;
- h. Conclusion — general summary.

- 2.3.4.1 TDs who are members of the IBU TC, must present their report to the following meeting of the TC.

2.4 TD TASKS AT EVENTS

TDs must perform the following tasks at events:

2.4.1 Tasks Prior to Events

TDs must arrive in due time before the start of the Official Training to check whether the competition venue meets all requirements for training and competition and to ascertain where changes are

required. They must make immediate contact with the Organizing Committee to ensure that:

- a. Team Captains Meetings and draws are prepared;
- b. arrangements for the assembly of the Juries have been made;
- c. the entries of the participating nations were received in time;
- d. corresponding plans for the reception of the teams are ready;
- e. the costs for the teams are the same as those stated in the application to host the event.

2.4.2 Tasks During Events

2.4.2.1 General

The TD must work closely with the Competition Chief during the event and each competition, ensuring that all operations are conducted correctly, without incidents and in accordance with the IBU Event and Competition Rules and other pertinent IBU regulations.

2.4.2.2 Meetings

The TD must take part in all the meetings of the Organizing Committee, the team captains and the Competition Juries, as well as at all draws.

2.4.2.3 Responsibility to IRs

The TD must keep IRs briefed on the current situation and engage in their activities in a directing and coordinating manner.

2.4.2.4 IBU Race Director

The TD shall communicate and cooperate with the IBU Race Director.

2.4.3 Tasks Prior to Competitions

2.4.3.1 TV Zones

The TD shall assist the IBU Race Director and TV advisor to establish TV zones in consultation with TV representatives, IR Course and the OCs, including location, size, required fencing and enforcement methods and personnel.

2.4.3.2 Information Channels

The TD shall hold a meeting with the IRs to brief the IRs on the plans for the competition and the telecommunications available during the competition, and to assign tasks. This meeting can also be combined with the meeting that is held by the Competition Chief with his chiefs prior to each competition.

2.4.3.3 Inspections

The TD shall make a general inspection of the venue.

2.4.3.4 Reports

The TD shall obtain status reports from the IRs and the Competition Chief.

2.4.3.5 Competition Jury Meeting

The TD shall hold a meeting of the Competition Jury one hour before the first start to determine if conditions are suitable for the competition. The TD must obtain reports from the IRs about their areas of operation and from the Competition Chief prior to this meeting.

2.4.4 Tasks During Competitions

2.4.4.1 General

The TD shall oversee and coordinate the work of the Competition Chief and the IRs, receive reports on the progress of the competition and take remedial actions as necessary.

2.4.4.2 Competition Jury Meetings

The TD shall hold meetings of the Competition Jury as required.

2.4.5 Tasks After Competitions

2.4.5.1 Last Finish

With the Competition Chief, the TD shall direct and coordinate the critical phase that starts immediately after the last finish.

2.4.5.2 Provisional Results

The TD shall confirm the correctness of the Provisional Results, sign the result lists and authorize their posting, and record the time of posting on the results.

2.4.5.3 Flower Ceremony

The TD shall authorize the conduct of the unofficial awards ceremony when he is satisfied that the first necessary placings are confirmed. It must be noted that there may be a later protest and that the unofficial ceremony is at the risk of the OC.

2.4.5.4 Event Points

The TD must ensure that the OC calculates the WC, Nations Cup or other applicable event points correctly.

2.4.5.5 Evaluation

The TD shall hold an evaluation meeting about the competition with the Competition Chief and his chiefs and the IRs.

2.4.6 Tasks After the Event

2.4.6.1 WC Points

The TD shall ensure that the lists of WC, Nations Cup or any other event points are sent immediately to the next OC of a WC or other event.

2.4.6.2 Event Evaluation

The TD shall hold an evaluation meeting about the entire event for all Organizing Committee chiefs and the IRs.

2.4.6.3 Written Report

The TD shall prepare a written report about the event and send it to the IBU SG, to the Event Host and the Chairman of the Organizing Committee not later than one month after the event. A prepared IBU TD report form for this purpose will be distributed by the Chairman of the TC Referee Sub-Committee to all TDs appointed for the coming season.

2.4.6.4 Report at TC Meeting

IBU TDs who are members of the TC shall report on the event at the next meeting of the IBU TC.

3. INTERNATIONAL REFEREES

3.1 GENERAL

The general regulations for the selection, appointment and the work of IRs are provided in the IBU Event and Competition Rules. This annex supplements the general regulations by detailing specific duties of IRs.

3.1.1 Principles of the IR Function

IRs, like TDs, have the responsibility of being the technical representatives of the IBU at an event, in their area of responsibility and under the direction of the TD. Within their area of responsibility, all of the principles that apply to the TD function shall apply to IRs, except being in the Competition Jury.

3.1.2 Notification of Appointment and Preparation

Shortly after being appointed for an event, the IR will be notified of the appointment by the IBU SG. The IR will not be required to establish formal contact with the OC except for travel and accommodation arrangements. Once notified of the appointment, the IR must prepare so that he is fully conversant with the current IBU rules and regulations for his area of responsibility.

3.2 IR TASKS AT EVENTS

IRs shall have the following tasks at an event:

3.2.1 Tasks Prior to Events

IRs must arrive at the event site in time to prepare prior to the first Official Training; the IR Material Inspection must arrive in time for the preliminary inspection of equipment. On arrival they must report to the TD to announce their presence and to receive briefings and directions. Then they must contact the chiefs from the Organizing Committee for their areas of responsibility and review arrangements, and inspect their areas. The checklist in the Organizers' Guide should be used as a guide. If there are problems, they must be reported to the TD.

3.2.2 Tasks Prior to Competitions

In preparation for each competition, the IRs must:

- attend all Team Captains Meetings, any other meetings as directed by the TD and meetings held by the chiefs of their areas;
- carry out a detailed inspection of their areas and check all plans using the checklist to ensure they are in accordance with the Rules, and direct corrections to be made as necessary;
- remain in their areas to oversee preparations and activities;
- report to the TD when their areas are ready for the competition;
- carry out other tasks as directed by the TD.

3.2.3 Tasks During Competitions

During each competition the IRs must:

- remain in their areas to supervise all activities to ensure the correct and orderly conduct of the part of the competition that is their responsibility;
- intervene to stop an error from being made;
- assist and advise the Organizing Committee officials if required;
- ensure all safety precautions are being adhered to;

- report to the TD when significant occurrences take place such as first start, last start, first shooter on the range, last shooter on the range, first finish, etc., and if any unusual incident occurs such as an injury, etc.;
- observe violations of the Rules and report them to the TD;
- carry out any other tasks as directed by the TD.

3.2.4 Tasks After Competitions

At the end of each competition IRs must:

- report to the TD that all is clear for their area or report the problems that have occurred and have not been previously reported; these reports must be made immediately if possible, in order to assist the speedy posting of the Provisional Results and the conduct of the unofficial awards ceremony;
- report to the Competition Jury about the circumstances of penalties, when so directed;
- hold a short evaluation meeting about the competition for the chief and supervisors of the respective area.

3.3 IR AUTHORITY, RESPONSIBILITIES AND ORGANIZATIONAL RELATIONSHIPS**3.3.1 Authority**

IRs are responsible and subordinate to the TD for the appropriate preparations and the correct and orderly conduct of competitions in their areas of responsibility. IRs shall not be in charge of the conduct of activities in their areas, but shall be responsible to ensure that all routines are correct. They must maintain close contact with the chiefs of their areas during the entire event in order to fulfill their tasks.

3.3.2 Specific Areas of Responsibility

The specific areas of responsibility for IRs within their general areas shall be:

- IR Course: all course matters including configurations of loops, technical specifications, grooming, signage and fencing, inspection and checkpoints, access control, TV zones layout and their enforcement, forerunners, communications, safety and first aid arrangements;
- IR Range: all range matters including layout and configurations, specifications, targets and their operation, penalty loop, coaches enclosure, signage and numbering, lane markings, wind flags,

- rifle racks, relay cups, grooming, scoring, control procedures, telecommunications, and safety;
- c. IR Start/Finish: all start/finish area matters and timing systems including layout, configurations, specifications, relay hand-over zone, start clock and course sequence board, photo-finish camera for Pursuit, Mass Start and Relay competitions, acting as the photo-finish judge, and finish video camera for all competitions, warm-up area, storage areas for competitors' clothing, grooming, signage and fencing, traffic flow and control, start and finish procedures, telecommunications, timing procedures and equipment, and safety;
- d. IR Material Inspection: all equipment/material inspection matters including timings, inspection equipment, preliminary equipment/material inspection, start and finish inspection layouts (in consultation with IR Start/Finish), inspection procedures, traffic flow and control, telecommunications, and safety.

3.3.3 Organizational Relationships

The primary relationships for IRs with the Organizing Committee (direct liaison) shall be as follows:

- a. IR Course - Chief of Course;
- b. IR Range - Chief of Range;
- c. IR Start/Finish - Chief of Timing (may be regulated differently by some OCs);
- d. IR Material Inspection - Chief of Timing and/or Material Inspection Supervisor.

ANNEX C TRAINING AND LICENSING OF TECHNICAL DELEGATES AND INTERNATIONAL REFEREES

ANNEX C

TABLE OF CONTENTS

1.	GENERAL	
1.1	Jurisdiction	2
1.2	Qualification Levels	2
1.3	Eligibility for Appointment	3
1.4	Age Limits	3
1.5	Terminology	3
2.	SELECTION, TRAINING AND TESTING	
2.1	Selection Procedure for Certification	3
2.2	Training	5
2.3	Testing	7
3.	LICENSING	
3.1	Recognition of Qualification	7
3.2	Issue, Format, Validity and Conditions of Licenses	8
4.	QUALIFICATION AND APPOINTMENT BADGES	
4.1	Qualification Badges	9
4.2	Appointment Markings.....	10
5.	EMPLOYMENT OF TDS AND IRS	
5.1	General	10
5.2	Employment Guidelines	10
6.	FINANCIAL MATTERS	
6.1	TD and IR Expenses	11
6.2	Financial Conditions for Seminars and Testing	11

1. GENERAL

The IBU has a training, licensing and employment system for technical officials in order to ensure that all IBU officials working at IBU events perform their duties effectively and correctly, with a common training standard. The Rules direct the appointment and duties of technical officials (TDs and IRs) for IBU events. This Annex details the training, testing, licensing and employment conditions for technical officials.

1.1 JURISDICTION

All aspects of selection, training, testing and licensing of Biathlon technical officials at international level is to be under the jurisdiction of the IBU TC. The TC Referee Sub-Committee will be responsible for implementation and administration of the system applying to officials.

1.1.1 Liaison

NFs may discuss matters concerning technical officials directly with the Chairman of the Referee Sub-Committee or the IBU SG. NFs will be requested to appoint a contact person within their area responsible for technical officials and to provide the Chairman of the Referee Sub-Committee with the contact information for that person.

1.2 QUALIFICATION LEVELS

There are two levels of qualification for IBU technical officials:

- Technical Delegate (TD);
- International Referee (IR).

1.2.1 Intended Roles of TDs and IRs

Officials will be trained and licensed for the following purposes:

1.2.1.1 TDs

The TD qualification is primarily intended to train an official to function as a TD at IBU events. Persons qualified to be a TD may also fulfill any IR function at IBU events and may hold positions corresponding to those of an IR in an organizing committee.

1.2.1.2 IRs

The purpose of the IR qualification is to train and certify officials who can function in IR positions at IBU events and who can hold IR designated positions in organizing committees. As well, the certified IRs will form the pool of qualified persons from which candidates will be selected for further training for the TD qualification.

C/2

EDITION 2006

1.3 ELIGIBILITY FOR APPOINTMENT

In order to be eligible for appointment to function as a TD or IR at IBU events, an official must hold the necessary qualification and the required valid license for the position.

1.4 AGE LIMITS

The following age limits shall apply for the certification and employment of TDs and IRs:

1.4.1 TDs

1.4.1.1 TD Test

Persons wishing to sit the TD qualification test must be at least 28 and not older than 55 years of age.

1.4.1.2 Assignment of function of TD at an IBU Event

Persons may not be assigned the function of TD at an IBU event if they are older than 65 years of age.

1.4.2 IRs

1.4.2.1 IR Test

Persons wishing to sit the IR qualification test must be at least 22 and not older than 57 years of age.

1.4.2.2 Employment as IR at an IBU Event

Persons may not be employed as an IR at an IBU event if they are older than 65 years of age.

1.5 TERMINOLOGY

It must be noted that the terms TD and IR are the names of both the levels of qualification and the position titles when appointed for an IBU event. Should confusion arise in the use of the terms for both purposes in one context, the qualification terms shall be indicated as TD (Q) and IR (Q)

2. SELECTION, TRAINING AND TESTING

Selection, training and testing of candidates for TD and IR qualification shall be done as follows:

2.1 SELECTION PROCEDURE FOR CERTIFICATION

2.1.1 TDs

Candidates for TD qualification shall be selected by the IBU TC from among the qualified IRs, based on observed performance. However,

EDITION 2006

C/3

NFs may nominate suitable IRs as candidates for consideration by the TC.

2.1.1.1 TD Prerequisites

- a. The candidate must have clearly proven his suitability as an IR and must be able to function in a senior leadership role in conditions of extreme stress and in view of the fact that an error could have the highest level of consequences. In addition, he must be capable of negotiating and liaising successfully with senior members of Organizing Committees, representatives of the media and with dignitaries;
- b. The candidate must have and have held a valid IBU IR license for at least four years and must have officiated in at least two international events during the past four years;
- c. The candidate must be within the TD age limits.

2.1.1.2 TD Quota

Candidates shall be selected for TD training and certification in sufficient numbers to maintain the required number of TDs within the TD Group and the necessary reserves as determined by the TC.

2.1.2 IRs

2.1.2.1 IR Applications

Candidates shall be selected for training and licensing as IRs based on a nomination by their NF, in writing, to the Chairman of the IBU TC Referee Sub-Committee. Applications must be sent by the deadline date given in the seminar invitation or by 31 May in the case of a test under special circumstances. Applications must include the following information:

- a. full name, date and place of birth, gender, nationality, full residence, address, phones, fax, e-mail address;
- b. mother tongue and command of other languages;
- c. language in which the test is to be held;
- d. seminar location and dates;
- e. length and type of experience as a national referee.

2.1.2.2 IR Requirements

All candidates must meet the applicable prerequisites for IRs. NFs shall be required to screen their nominations with regard to general suitability and prerequisites, and to confirm in their nominations that

the person meets all necessary criteria. Final acceptance of a candidate into the program shall then be decided by the IBU TC.

2.1.2.3 IR Prerequisites

- a. The candidate must be able to perform very responsible duties with a high consequence of error under stressful circumstances, in winter outdoor conditions, for long periods of time. The candidate must have sufficient skills in cross-country skiing to be able to ski on the competition course as necessary;
- b. The candidate must have and have held a valid national referee license for at least four years;
- c. The candidate must be within the IR age limits.

2.1.2.4 IR Quota

There is no set limit for numbers of IRs.

2.1.3 The TD Group

The TD Group will be established under the control of the TC and shall consist of 30 or more qualified TDs with the applicable licenses plus all of the members of the TC – i.e. a total of 40 or more. All TDs appointed for IBU events shall be from the TD Group. There should be at least one TD from every continent in the TD Group. A TD will retire from the TD Group when he reaches the age of 65.

2.2 TRAINING

2.2.1 General

Training of TDs and IRs will be conducted at seminars instructed by members of the IBU TC. Seminars will be held in various regions of the world, according to requirement. Scheduling of the seminars will be decided by the IBU EB based on recommendations of the TC. TD seminars will be held at least once every two years.

2.2.2 Seminar Specifications

The following specifications shall apply to TD and IR seminars:

2.2.2.1 TD Seminars

- a. Duration – 22 hours, including the test;
- b. Candidates – maximum 15, minimum 5;
- c. Instructors – IBU Race Director, Chairman of the IBU TC Referee Sub-Committee plus one or two other members of the TC as directed by the TC;

- d. Language – English and/or German or Russian with translation as required.

2.2.2.2 IR Seminars

- a. Duration – 18 hours, including the test;
- b. Candidates – maximum 25, minimum 5;
- c. Instructors – two members of the TC appointed by the IBU TC Referee Sub-Committee;
- d. Language – as required.

2.2.3 Attendance of Observers

The TC may authorize the attendance of observers at IR seminars. These persons will normally be national referees who will not sit any test, or qualified IRs who are doing refresher training for themselves, or other interested persons.

2.2.4 NF Sponsored Seminars

A seminar with a test may be held at the request of a NF if there are a sufficient number of eligible candidates and the NF(s) will pay all costs for instructors provided by the IBU and the seminar. The final decision for the approval of such a seminar shall rest with the IBU TC.

2.2.5 Seminar Content

- The TD and IR seminars will be held in accordance with a standardized seminar training plan established by the TC for them and which will include:
- a. General Information about the Biathlon TD and IR System, the IBU, Definitions, History;
 - b. Classes of Competitors and Types of Competitions, Competitor Qualification Entries;
 - c. Organizations and Duties: Organizing and Competition Committees, Juries, TDs, IRs;
 - d. Preparations for Competitions: Training, Team Captains Meetings, Draws, Facility Preparations, Equipment Checks, Zeroing;
 - e. Implementation of Competition Rules: Use of the Rules and regulations, Equipment and Measuring Devices, Advertising, Start, Skiing, Shooting, Finish, Penalties and Protests;
 - f. Competition Activity: Supervising Officials, Monitoring Competition Activity, Timing, Forms, Results, Communications and Reports;

- g. Case studies (Competition Jury cases, etc.) – at TD seminars only;
- h. Test.

2.3 TESTING

All TD and IR candidates must successfully complete a written test or oral examination in order to become a qualified TD or IR. The test shall be conducted in conjunction with TD and IR seminars; in exceptional circumstances the TC may set other test dates.

2.3.1 Test Formats

Tests shall be formulated by the IBU TC Referee Sub-Committee, with changes for each individual test. The candidates will be asked questions that will test knowledge required by TDs and IRs for conducting their duties. Tests must be done without the use of any reference material. The following test specifications shall apply:

- a. Questions – TD: 35, IR: 25;
- b. Allowed time – 120 minutes;
- c. Pass Grade – if 80 % of all questions have been answered correctly.

2.3.2 Scoring of Tests

Tests shall be marked according to the standard marking guide established by the TC.

2.3.3 Supplementary Questions

The TC may direct that supplementary questions are to be answered during the test.

2.3.4 Test Languages

TD tests must be given and answered in English, German or Russian, however the TC may authorize exceptions as required. IR tests may be administered in any language, as appropriate for the circumstances.

3. LICENSING

3.1 RECOGNITION OF QUALIFICATION

Following attendance at a seminar and completion of the test to the required standard, successful TD and IR candidates will be reported to the next meeting of the IBU TC. If no other circumstances exist as grounds for denial, the TC shall appoint all persons who have passed the seminar and test TD or IR, respectively.

3.2 ISSUE, FORMAT, VALIDITY AND CONDITIONS FOR LICENSES

3.2.1 Issue

Following approval by the TC, a license will be issued to a TD or IR and will be effective from the date of the issue.

3.2.2 Format

Licenses issued to IRs and TDs must contain the following information:

3.2.2.1 TD AND IR

- a. type of qualification – TD or IR;
- b. full name, date of birth, gender, nationality;
- c. period of validity and extensions;
- d. photo of the holder, impressed with the IBU seal;
- e. signature of the Chairman of the TC or his appointee.

3.2.2.2 TD – Additional Information

- a. record of employment at IBU events signed by the TD of the event – or the Chairman/Competition Chief of the Organizing Committee if the license holder was himself the TD there – and must be stamped with the OC's seal;
- b. qualification record – dates of qualification as national referee, IR and TD;
- c. record of IR and TD seminars attended;
- d. biennial license validity stamp.

3.2.3 Periods of Validity

TD and IR licenses are valid for two years (TD) and for four years (IR) from the date of issue and may be renewed for further such periods without any other limit than the age, and as long as no factors exist as grounds for denying a renewal.

3.2.3.1 Renewal Process

TD and IR licenses may be renewed after the expiry of their validity period. For this purpose the NF of the official must submit a written request, accompanied by the license, to the Chairman of the TC Referee Sub-Committee. The requests for renewal must be submitted prior to the expiry date of the license for IRs and by 31 May prior to expiry for TD licenses.

3.2.3.2 Biennial Validation of TD Licenses

NFs or TDs must send TD licenses for biennial validation to the Chairman of the IBU TC Referee Sub-Committee by 30 April of a given year. If all circumstances are in order, the license will be stamped in the biennial validation record and returned.

3.2.3.3 Retention of TD License

Even though a TD is no longer a member of the TD Group for reasons other than age, disciplinary reasons or incompetence, his license may be renewed and validated, as long as all other factors required for its validity are maintained.

3.2.4 Revoking a License

A license may be taken away from a TD and IR for disciplinary reasons or for other reasons having to do with that person. The process for revoking a license shall be initiated by a corresponding recommendation by the Chairman of the IBU TC Referee Sub-Committee to the TC. After thoroughly investigating all circumstances relating to the case, the TC may propose to the IBU EB to revoke the license, subject to the provisions of the IBU Disciplinary Rules.

4. QUALIFICATION AND APPOINTMENT BADGES

Distinctive qualification and appointment badges and markings will be issued to TDs and IRs. It is the right of every TD and IR with a valid license to wear the appropriate qualification badge at any time.

4.1 QUALIFICATION BADGES

Badges of qualification will be issued to TDs and IRs at the same time as their licenses are granted, as follows:

4.1.1 TD

TDs will be issued a metal badge of gold color with the IBU Logo and the words "Biathlon Technical Delegate" imprinted. Prior to issue, the name of the recipient shall be engraved on the badge.

4.1.2 IR

IRs will be issued a white and gold colored metal badge with a Biathlete figure and the words International Referee imprinted. As well, each IR badge will have an imprinted sequential issue number.

4.2 APPOINTMENT MARKINGS

TDs and IRs appointed to specific positions as TDs and IRs at IBU events shall be issued a distinctive marking to identify them as having responsibility for that position. The markings may be a badge, armband or item of clothing and must clearly indicate the bearer's IBU TD or IR qualification, as appropriate. The IBU TC will periodically direct what types of marking will be used by what TDs and IRs appointed for what IBU events.

5. EMPLOYMENT OF TDs AND IRs**5.1 GENERAL**

TDs and IRs shall be appointed for OWG, WCH, Y/JWCH, WC, CCH, CC, Continental Games, CISM, EYOF, the University Games and other IBU events by the IBU TC based on the recommendation of the IBU TC Referee Sub-Committee. TDs for events not under IBU jurisdiction shall be appointed only if requested by the responsible body for the event.

5.1.1 New TD Employment

Newly qualified TDs may be employed only as IRs at IBU events during the first two years after their qualification. The TC may authorize exceptions to this restriction if circumstances so demand.

5.2 EMPLOYMENT GUIDELINES

Appointment of TDs and IRs is to be based on the principle of utilizing the best and the most experienced officials for each event while at the same time providing development opportunities for less experienced officials. Factors such as language capability and travel costs must be considered as well. As many different officials as possible should be employed on an alternating basis.

5.2.1 OWG Preparation

Senior officials of the Organizing Committee for the next OWG, such as the Competition Chief, Chiefs of Course, Range and Timing, should be considered as candidates for TDs and IRs at a preceding WCH, if appropriate and possible.

5.2.2 Regulations for the Employment of Officials

The TC shall appoint the TDs and IRs from among its members and the TD group for the following IBU events:

- a. OWG – 2 TDs, 8 IRs;
- b. WCH – TD, 4 IRs;
- c. Y/JWCH – TD, 4 IRs;
- d. WC – TD, 3 IRs, 1 IR (NF);
- e. ECH – TD, 4 IRs;
- f. EC – TD, 1 IR, 3 IR (NF);
- g. Other CCH – TD;
- h. Other CC – TD;
- i. CISM, University Games, Continental Games, EYOF – TD;
- j. Summer Biathlon WCH, – TD, IR

6. FINANCIAL MATTERS**6.1 TD AND IR EXPENSES**

TDs and IRs shall receive a daily allowance for each travel and work day arising from IBU duties, and reimbursement of travel expenses, in accordance with the current IBU Rules for Travel Expenses.

6.2 FINANCIAL CONDITIONS FOR SEMINARS AND TESTING

Financial remuneration for TD and IR holding seminars and tests shall be directed by the IBU EB.

ANNEX D RULES FOR CONTINENTAL CHAMPIONSHIPS

ANNEX D

TABLE OF CONTENTS

1.	EUROPEAN CHAMPIONSHIPS	
1.1	General	2
1.2	Event and Competition Rules	2
2.	NORTH AMERICAN CHAMPIONSHIPS	
2.1	General	2
2.2	Competitions	3
2.3	Champions and Participation.....	3
2.4	Invitations, Registration and Entries	3
2.5	Rules	4
2.6	Awards	4
3.	ASIAN CHAMPIONSHIPS	4
4.	SOUTH AMERICAN CHAMPIONSHIPS	
4.1	General	5
4.2	Competitions	5
4.3	Champions and Participation.....	5
4.4	Invitations, Registration and Entries	5
4.5	Rules	6s
4.6	Awards	6

1. EUROPEAN CHAMPIONSHIPS

1.1 GENERAL

1.1.1 Participants

The NFs may register up to eight competitors in each class to participate in the ECH and eight team staff per NF team. Four competitors of each NF will be eligible to start in the Individual and Sprint competitions. Each NF may enter one Relay team for the Relay competition. The 60 best competitors of the qualification competition of each class will be eligible to start in the Pursuit competition. Additionally, the NFs of the Individual and Sprint champions of the previous year's ECH will be granted the right to enter them at the ECH. Individual and Sprint competitions, in addition to their NF's quota.

1.2 EVENT AND COMPETITION RULES

1.2.1 Scope

The IBU Event and Competition Rules shall apply for the ECH with the following deviations:

1.2.1.1 Classes of Competitions

At ECH no separate competitions for youth will be organized.

1.2.1.2 Start Sequence in Relay and Pursuit Competitions

The classes will start in the following sequence:

- Men - Junior Men
- Women - Junior Women.

2. NORTH AMERICAN CHAMPIONSHIPS

2.1 GENERAL

The NACH is an event of the IBU and is held annually under its control, hosted by an IBU member NF from North America, for Men, Women, Junior Men, Junior Women, Youth Men and Youth Women.

2.1.1 Joint Events

The NACH may also be an event of the NAC series but the NAC may not interfere with or in any way reduce the prominence or importance of the NACH.

2.2 COMPETITIONS

The NACH is a joint event held for the authorized classes and will consist of the following competitions for each class: Individual, Sprint, and Relay. Other competitions authorized by the IBU, including the Pursuit and Mass Start may be added at the discretion of the North American NFs with the agreement of the IBU TD.

2.3 CHAMPIONS AND PARTICIPATION

2.3.1 CHAMPIONS

The NACH is intended to result in North American Biathlon champions in each respective class and competition every season. Therefore, although Biathletes of all IBU member nations may participate, all North American champions must, at the time of the NACH, be a valid member of a team from a North American IBU member federation.

2.3.2 Participation

As there are so few North American Member Federations, all participating nations may enter teams based on states, provinces or territories, and regions that represent combinations of states, provinces or territories. Teams exclusively from the North American NFs will not be permitted. However, the champion of each class and competition shall be declared under the actual name of the North American NF.

2.4 INVITATIONS, REGISTRATION AND ENTRIES

2.4.1 Invitations

Invitations shall be sent as stipulated in the IBU Event and Competition Rules for WC events.

2.4.2 Registration and Entries

Each NF entitled to enter teams in the NACH, may register, for each participating team, 6 competitors in each class and may enter 4 competitors of each class in each Individual and Sprint competition. Each NF may enter one official Relay team per participating team.

2.4.2.1 Extra Relay Teams

Extra and mixed state, province, territory and region Relay teams may be permitted with the agreement of both the OC and the TD, but these unofficial teams shall not be eligible to be North American champions. The decision to allow unofficial Relay teams may be

made during the Championships, taking into account the number of teams participating.

2.4.2.2 Team Staff

A minimum of 5 team staff per participating team must be allowed to be registered for the NACH, but the number may be increased by the OC with the agreement of the TD. If the number of permitted team staff is increased, the number of team staff allowed to be registered must be notified in the invitation.

2.5 RULES

2.5.1 Application of IBU Rules

The IBU Event and Competition Rules shall apply fully to the NACH unless they are clearly not applicable and if other rules are specified in this Annex, and with the following exceptions:

- 2.5.1.1 Facility requirements for the NACH may be modified with the approval of the TD.
 - 2.5.1.2 The Junior Men's and Women's Relay competitions shall consist of teams with 3 members.
 - 2.5.1.3 Each official team's start position in the Relay competition shall be determined for each class by a single random draw, including the first start row. Extra teams must be started immediately behind the official teams and their positions shall be determined by a single, separate, random draw for the unofficial teams. The row designated as the last start row for the official teams may not include unofficial teams.
 - 2.5.1.4 If necessary, other IBU Rules and regulations, such as advertising regulations, may be modified with the approval of the IBU TC or EB, as applicable.
- #### 2.6 AWARDS
- IBU medals will be awarded in accordance with the IBU Event and Competition Rules, Chapter 14. OCs may optionally give awards or prizes to additional placings in all or some competitions or for all or some of the classes.

3. ASIAN CHAMPIONSHIPS

These rules will be printed at a later time.

4. SOUTH AMERICAN CHAMPIONSHIPS

4.1 GENERAL

The South American Championships (SACH) is an event of the IBU and is held annually under its jurisdiction, hosted by an IBU member NF that is also a South American NF, for Men, Women, Junior Men and Junior Women. Other classes of competitors may be allowed to participate with the agreement of both the OC and the TD. If other classes are permitted to participate, it must be notified in the invitation.

4.2 COMPETITIONS

The SACH is a joint event held for the authorized classes and will consist of the following competitions for each class: Individual, Sprint, and Relay. Other competitions authorized by the IBU including the Pursuit and Mass Start may be added at the discretion of the South American NFs with the agreement of the IBU TD.

4.3 CHAMPIONS AND PARTICIPATION

4.3.1 Champions

The SACH is intended to result in South American Biathlon champions in each class and competition every year. Therefore, although Biathletes of all IBU member nations may participate, all South American champions must, at the time of the SACH, be valid members of a team from a South American IBU Member Federation.

4.3.2 Participation

The NFs of South America may register up to ten competitors in each class to participate in the SACH. Eight competitors from each NF will be eligible to start in the Individual and Sprint competitions. Each NF may enter two Relay teams.

4.4 INVITATIONS, REGISTRATION AND ENTRIES

4.4.1 Invitations

Invitations shall be sent as stipulated in the IBU Event and Competition Rules.

4.4.2 Registration and Entries

Each NF from South America may register its participants in accordance with article 4.3.2 above.

4.5 RULES

4.5.1 Application of IBU Rules

The IBU Event and Competitions Rules shall apply fully to the SACH unless they are clearly not applicable and if they are specifically modified in this Annex, with the following exceptions:

4.5.1.1 Venue requirements for the SACH may be modified with the approval of the TD.

4.5.1.2 The Junior Men's and Junior Women's Relay competitions shall consist of Relay teams with 3 members each.

4.6 AWARDS

4.6.1 IBU medals will be awarded in accordance with article 14.1.6 of the IBU Event and Competition Rules. OCs may optionally give additional awards or prizes in all or some competitions and for all or some of the classes.

ANNEX E

RULES FOR CONTINENTAL CUP EVENTS

ANNEX E

TABLE OF CONTENTS

1.	EUROPEAN CUP EVENTS	
1.1	General	2
1.2	Competitors and Entries	2
1.3	Scoring	2
1.4	Awards	3
1.5	Competition Rules	3
2.	NORTH AMERICAN CUP EVENTS	
2.1	General	3
3.	ASIAN CUP EVENTS	
3.1	General	3
4.	SOUTH AMERICAN CUP EVENTS	
4.1	General	3

1. EUROPEAN CUP EVENTS

1.1 GENERAL

The number of EC events in each competition season shall be set by the IBU EB upon recommendation by the TC. The TC shall make recommendations to the EB, which will decide how many and what types of competitions shall be organized at an event. This information shall be included in the IBU Biathlon calendar. The competitions of the ECH shall be included in the EC scoring.

1.2 COMPETITORS AND ENTRIES

Each IBU Member Federation may register and enter up to ten competitors in each class, Men, Women, Junior Men and Junior Women. All entered competitors shall be eligible to win EC points.

1.3 SCORING

European Cup points shall be awarded at each EC as described in the Rules for the World Cup.

1.3.1 Types of Scoring

There shall be the following types of scoring for Men, Women, Junior Men and Junior Women:

- a. EC Total Score (Individual, Sprint, Pursuit);
- b. EC Individual Score;
- c. EC Sprint Score;
- d. EC Pursuit Score.

1.3.2 EC Total Score

Three results can be deleted from the total of all scores in EC events and the ECH in the competitions listed in article 1.3.1 a.

1.3.3 EC Individual Competition

One competition of the Individual competitions in the EC and ECH can be deleted.

1.3.4 EC Sprint Competition

One competition of the Sprint competitions of the EC and ECH can be deleted.

1.3.5 EC Pursuit Competition

One competition of the Pursuit competitions of the EC and ECH can be deleted.

1.4 AWARDS

1.4.1 The competitors placed first in the competitions listed under article 1.3.1 a–d shall be awarded a European Cup.

1.4.2 The European Cup Trophies shall be paid by the IBU.

1.5 COMPETITION RULES

1.5.1 Scope

The IBU Event and Competition Rules shall be applied to the EC events; however, there shall be the following deviations:

1.5.1.1 Pursuit Competition

Lapped competitors may finish the competition. The start sequence of the categories and the zeroing times will be established by the Team Captains Meeting for the competition.

2. NORTH AMERICAN CUP EVENTS

2.1 GENERAL

A NAC events series will be conducted annually in Canada and the United States, with an east and west circuit, with scheduling, locations, programs and special rules directed by US Biathlon and Biathlon Canada. The IBU Event and Competition Rules will be used wherever applicable.

3. ASIAN CUP EVENTS

3.1 GENERAL

AC events will be held as agreed upon by the NFs of the continent, using the IBU Event and Competition Rules applicable.

4. SOUTH AMERICAN CUP EVENTS

4.1 GENERAL

SAC events will be held as agreed upon by the NFs of this continent, using the IBU Event and Competition Rules as applicable.

ANNEX F

COMPETITION RULES FOR SUMMER BIATHLON

ANNEX F

LIST OF CONTENTS

1.	CROSS BIATHLON	
1.1	General Regulations	2
1.2	Competition Specifications	2
1.3	Competition Venues	4
2.	ROLLER BIATHLON	
2.1	General Regulations	5
2.2	Competition Specifications	5
2.3	Competition Venues	5
2.4	Shooting Regulations	6
2.5	Registration and Entry at WCHs	6
3.	MOUNTAIN BIKE BIATHLON	
3.1	Definition	6
3.2	Classes of Competitors	7
3.3	Competitions	7
3.4	Draw of start numbers by classes	7
3.5	Competition Jury	7
3.6	Competition Venue and Facilities	7
3.7	Competition Equipment and Clothing	8
3.8	Training and Zeroing	8
3.9	Shooting Regulations	8
3.10	Penalties	8
3.11	Ranking	8

1. CROSS BIATHLON

1.1 GENERAL REGULATIONS

Cross-country running and small-bore shooting (Cross Biathlon) is a form of Summer Biathlon, which is conducted in a similar fashion to Winter Biathlon, without snow and skis. In principle, all IBU Event and Competition Rules shall apply unless other regulations are formulated in this Annex.

1.1.1 Rifle Usage

The rifle will not be carried by the competitor while running but will be left at the shooting range in a rack, and will be picked up by the competitor for each shooting bout. The competitors themselves will remove the rifles from the rifle rack by grasping the barrel, or the forestock, and then carrying it to the shooting lane, with the barrel pointing upwards at all times. The same method will be used to return the rifles to the racks after each bout of shooting. The carrying harness may be left on the rifle, or it may be removed. Competitors must deposit their rifles in the racks not later than 5 minutes before the first start, and will not be permitted to start if they have not done so. Rifles must not be removed from the racks until the entire competition is finished and all of the rifles have been inspected by the Referee.

1.1.2 Lapping

The winter rules for the Pursuit competition, which require the withdrawal of a competitor if lapped do not apply to Cross Biathlon competitions.

1.2 COMPETITION SPECIFICATIONS

Cross Biathlon will be conducted according to the following table:

**TABLE TO 1.2. – COMPETITION SPECIFICATIONS –
RUNNING AND SHOOTING**

1 Class of Competitor	2 Course Length and Competition Type	3 Shooting Bouts 5 Rounds per Bout except Relay	4 Shot Penalty
MEN	7 KM INDIVIDUAL	P, S, P, S	30 seconds
	4 KM SPRINT	P, S	70 m penalty loop
	6 KM PURSUIT	P, P, S, S	70 m penalty loop
	6 KM MASS START	P, P, S, S	70 m penalty loop
	4 x 4 KM RELAY	P, S (each) + 3 spare rounds per bout	70 m penalty loop
WOMEN	6 KM INDIVIDUAL	P, S, P, S	30 seconds
	3 KM SPRINT	P, S	70 m penalty loop
	5 KM PURSUIT	P, P, S, S	70 m penalty loop
	5 KM MASS START	P, P, S, S	70 m penalty loop
	4 x 3 KM RELAY	P, S (each) + 3 spare rounds per bout	70 m penalty loop
JUNIOR MEN	7 KM INDIVIDUAL	P, S, P, S	30 seconds
	4 KM SPRINT	P, S	70 m penalty loop
	6 KM PURSUIT	P, P, S, S	70 m penalty loop
	6 KM MASS START	P, P, S, S	70 m penalty loop
	3 x 4 KM RELAY	P, S (each) + 3 spare rounds per bout	70 m penalty loop
JUNIOR WOMEN	6 KM INDIVIDUAL	P, S, P, S	30 seconds
	3 KM SPRINT	P, S	70 m penalty loop
	5 KM PURSUIT	P, P, S, S	70 m penalty loop
	5 KM MASS START	P, P, S, S	70 m penalty loop
	3 x 3 KM RELAY	P, S (each) + 3 spare rounds per bout	70 m penalty loop

Notes to Table at 1.2

Column 1: Class of Competitor: according to these Rules.

Column 2: Course Length and Type of Competition: the required length of the course and the type of competition according to these Rules.

Column 3: Shooting Bouts: the number and sequence of shooting bouts and shooting positions.

Column 4: Shot Penalty: the automatically imposed penalty for each target not hit.

1.3 COMPETITION VENUES

The competition venues shall be arranged in general in conformity with Winter Biathlon rules, with the appropriate differences suitable for summer conditions naturally being considered. Requirements for the venue may be modified with the approval of the TD. All areas on which competitors run must be smooth, level and well packed with a firm surface that provides good traction for competitors in all summer weather conditions.

1.3.1 Course

Courses must be of a minimum width of 3 m and each course loop may be used as many times as required by the competition. The courses must be surfaced with grass, sawdust, asphalt or cinder and must be free of any obstacles or bumps. All parts of the course must be safe for the competitors running at full speed.

1.3.2 Start and Finish Zones

The start and finish zones must be flat and level and at least 5 m wide. The course after the start and the course before the finish must be straight for at least 50 m. Lanes for the Relay and Mass Start start area must be at least 1 m wide and 30 m long.

1.3.3 Shooting Range

The shooting range shall be constructed in accordance with the winter rules.

1.3.3.1 Rifle Racks

An adequate number of rifle racks must be located on the shooting range to allow each competitor a place for his rifle while he is running. Racks must be located so that each competitor runs the same distance with the rifle. The racks must be made of wood (metal causes damage to the rifle) and must facilitate easy deposit and removal of rifles by the competitors, and must prevent

accidental falling down of the rifles. The distance between the notches to accept the rifles must be at least 35 cm. The racks must be numbered with the start numbers of the competitors placed on the notches to indicate where the rifles must be placed. The numbers must be a minimum of 10 cm in height with line width of 1 cm.

1.3.4 Penalty Loop

The penalty loop must be 70 m (+ or - 5 m) in length.

2. ROLLER BIATHLON

2.1 GENERAL REGULATIONS

Roller skiing with small-bore shooting (Roller Biathlon) is a form of Summer Biathlon which is conducted in a similar fashion to Winter Biathlon, without snow. In principle, all IBU Event and Competition Rules shall apply unless other regulations are formulated in this Annex. The competitions may only be carried out with roller skis of the same type and model. The OC will announce this in the invitation. For the WCH, the IBU will define the type and model of the roller skis and provide these roller skis. Competitors must bring their own ski boots, bindings and helmets. Helmets shall be worn during all types of training and competition. The rifle will either be carried on the course or left at the shooting range. If the rifle is left at the shooting range, racks with numbers must be set up there. The racks are to be placed so that the track to and from the shooting lanes passes them. The invitation shall state whether the rifle will be carried during the competition or left at the shooting range.

2.2 COMPETITION SPECIFICATIONS

Roller Biathlon will be conducted according to Table 1 under Article 1.3.8 of the Event and Competition Rules. Any changes to the specifications, which must be authorized by the TD, must be stated in the invitation.

2.3 COMPETITION VENUES

Venues that have been specifically built for Winter Biathlon are particularly suitable for roller Biathlon competitions. However, the competitions can also be conducted on regular roads which are closed to traffic during the competition. All surfaces on which the competitors will roller ski must be asphalted.

2.3.1 Start Area

The start area for single starts must have a straight start line at right angles to the skiing direction. The start line for group or simultaneous starts must be placed so that the competitors have to ski the same distance.

2.3.2 Courses

The minimum width of the course shall be 3.5 m. Downhill parts and curves must be laid in such a way that the competitors are able to ski at full speed without risk of an accident. Using parts or sections of the course several times during one competition is permitted, provided the competitors do not interfere with or obstruct each other, or endanger themselves.

2.3.3 Shooting Range

Winter Biathlon regulations shall apply to the construction of shooting ranges.

2.3.4 Penalty Loop

A paved penalty loop of 150 m (+ or - 5 m) must be constructed according to Winter Biathlon rules.

2.4 SHOOTING REGULATIONS

The regulations valid for Winter Biathlon must be applied to Roller Biathlon with the exceptions listed below: a. the standing shooting lanes for roller skis must have wooden planks on which the shooter will stand during shooting and which will ensure that the wheels of the roller skis do not touch the ground; b. the competitors may stand on the planks on the shooting range so that the wheels of the roller skis do not touch the ground.

2.5 REGISTRATION AND ENTRY AT WCHS

NFs are allowed to register 8 competitors and enter 4 for the Senior classes, and register 5 competitors and enter 4 in the Junior classes.

3. MOUNTAIN BIKE BIATHLON**3.1 DEFINITION****3.1.1** Mountain Bike Biathlon is a summer sport combining mountain biking and smallbore rifle shooting.**3.2 CLASSES OF COMPETITORS**

Men and Women
15 – 20 years;
21 – 30 years;
31 – 40 years;
41 + years.

3.3 COMPETITIONS

Men 9 km (3-3-3) with two shootings (P, S);
Women 6 km (2-2-2) with two shootings (P, S).

3.3.1 Qualification if required by large entry numbers

Men 6 km (2-2-2) with two shootings (P, S);
Women 4.5 km (1.5-1.5-1.5) with two shootings (P, S).

3.4 DRAW OF START NUMBERS BY CLASSES

Group draw in every class; maximum of 4 draw groups per class.

3.5 COMPETITION JURY

1 TD appointed by IBU TC;
1 IBU International Referee;
1 UCI International Referee;
2 Team Captains.

3.6 COMPETITION VENUE AND FACILITIES**3.6.1 Start/finish**

a. Individual start at 60 second intervals;
b. Mass start.
Finish zone minimum 6 meters wide followed by a 10 x 30 meter slowdown area.

3.6.2 Course

Minimum of 2 loops consisting of varying terrain.

3.6.3 Penalty loop

A loop of mildly varying terrain, to provide a handicap of 30 seconds.

3.6.4 Shooting range

Following IBU Event and Competition rules, with the addition of bike and rifle racks.

3.7 COMPETITION EQUIPMENT AND CLOTHING

Competition equipment and clothing must be in accordance with IBU and UCI rules.

3.7.1 Inspection of equipment and clothing

Prior to the start and following the finish, equipment and clothing will be inspected by the IBU and UCI International referees.

3.8 TRAINING AND ZEROING

3.8.1 The day prior to the competition, competitors will have the opportunity to train on the competition course and range.

3.8.2 Zeroing will take place beginning one hour and ending 10 minutes prior to the start.

3.9 SHOOTING REGULATIONS

After placing the bike in the rack provided, the competitor will retrieve his rifle from the rack, place the rifle on his back in the carrying position, proceed to the appropriate shooting lane (prone or standing), fire 5 rounds, replace the rifle on his back in the carrying position, return the rifle to the rack and resume the race on his mountain bike. For each target missed the athlete must complete one penalty loop.

3.10 PENALTIES

3.10.1 IBU and UCI rules will be applied where appropriate.

3.10.2 Disqualification

- a. For not carrying the rifle on the back in the carrying position;
- b. For violating safety regulations.

3.11 RANKING

Competitors will be ranked according to their time taken (to 1/10 second) to complete the course.



IBU ANTI-DOPING RULES

TABLE OF CONTENTS

1. PRINCIPLES
 1.1 World Anti-Doping Code..... 2
 1.2 Definition of Doping 2
 1.3 Sphere of Application 4
2. OFFENCE OF DOPING AND ITS PUNISHMENT 4
3. PROOF OF DOPING 5
4. DOPING CONTROLS 5
5. SPECIAL SITUATIONS FOR SUBSTANCE USE IN SPECIFIED MEDICAL CONDITIONS 8
6. DOPING CONTROL LABORATORIES 9
7. DOPING CONTROL PROCEDURES
 7.1 Sampling, Responsibility and Organisation 10
 7.2 Urine Testing 11
8. BLOOD AND GENE CONTROLS
 8.1 Purpose 19
 8.2 Mode of Selection of Athletes for Blood Testing 19
 8.3 Collection of Blood Samples 20
 8.4 Analysis of Blood Samples..... 22
9. OUT OF COMPETITION CONTROLS
 9.1 Definition 24
 9.2 Sample Collection Personnel 24
 9.3 Mode of Selection of Athletes for Out-of-Competition Testing 25
 9.4 Independent Sampling Officer (ISO) 25
 9.5 Collection of Samples 25
10. ENTRY INTO FORCE 27

1. PRINCIPLES

1.1 WORLD ANTI-DOPING CODE

1.1.1 The IBU is subject to the World Anti-Doping Code and cooperates with the World Anti-Doping Agency (WADA) concerning its application and implementation. The IBU will automatically follow any amendments of the World Anti-Doping Code or any WADA Bylaw applicable to the IBU. The definitions contained in Appendix 1 to the World Anti-Doping Code are integral parts of these Rules.

1.2 DEFINITION OF DOPING

1.2.1 Doping is defined as the occurrence of one or more of the anti-doping rule violations set forth in Articles 1.2.2 through 1.2.9. The following constitute anti-doping rule violations:

1.2.2 The Presence of a Prohibited Substance or its Metabolites or Markers in an Athlete’s bodily Specimen.

Athletes are responsible for any Prohibited Substance or its Metabolites or Markers found to be present in their bodily Specimens. Accordingly, it is not necessary that intent, fault, negligence or knowing Use on the Athlete’s part be demonstrated in order to establish an anti-doping violation under Article 1.2.1.

a. Excepting those substances for which a quantitative reporting threshold is specifically identified in the Prohibited List, the detected presence of any quantity of a Prohibited Substance or its Metabolites or Markers in an Athlete’s Sample shall constitute an anti-doping rule violation.

b. As an exception to the general rule of Article 1.2.2, the Prohibited List may establish special criteria for the evaluation of Prohibited Substances that can also be produced endogenously.

1.2.3 Use or Attempted Use of a Prohibited Substance or a Prohibited Method.

The success or failure of the Use of a Prohibited Substance or Prohibited Method is not material. It is sufficient that the Prohibited Substance or Prohibited Method was Used or Attempted to be Used for an anti-doping rule violation to be committed.

- 1.2.4 Refusing, or failing** without compelling justification, to submit to Sample collection after notification as authorized in applicable anti-doping rules or otherwise evading Sample collection.
- 1.2.5 Violation of applicable requirements regarding Athlete availability for Out-of-Competition Testing** including failure to provide required whereabouts information and missed tests which are declared based on reasonable rules.
- 1.2.6 Tampering, or Attempting to tamper,** with any part of Doping Control.
- 1.2.7 Possession of Prohibited Substances and Methods:**
- Possession by an Athlete at any time or place of a Substance that is prohibited in Out-of-Competition Testing or a Prohibited Method unless the Athlete establishes that the Possession is pursuant to a therapeutic use exemption granted in accordance with Article 5.1 (Therapeutic Use) or other acceptable justification.
 - Possession of a substance that is prohibited in Out-of-Competition Testing or a Prohibited Method by Athlete Support Personnel in connection with an Athlete, Competition or training, unless the Athlete Support Personnel establishes that the Possession is pursuant to a therapeutic use exemption granted to an Athlete in accordance with Article 5.1 (Therapeutic Use) or other acceptable justification.
- 1.2.8 Trafficking in any Prohibited Substance or Prohibited Method.**
- 1.2.9 Administration or Attempted Administration of a Prohibited Substance or Prohibited Method** to any Athlete, or assisting, encouraging, aiding, abetting, covering up or any other type of complicity involving an anti-doping rule violation or any attempted violation.
- 1.2.10 Prohibited Substances and Methods for IBU Athletes means** any substance/method so described in the current WADA Prohibited List (including revisions that are continuously published by WADA). The WADA Prohibited List and all revisions shall go into effect for the IBU on 1 January of each year. The IBU will make the current WADA Prohibited List available to each National Federation

upon their request. It is up to each National Federation to ensure that the current WADA Prohibited List is available to its members.

1.3 SPHERE OF APPLICATION

- 1.3.1 These Rules shall apply** to each National Federation and each participant in the activity of the IBU or any of its National Federations by virtue of the participant's membership, accreditation or participation in the IBU or its National Federation activities or events.
- 1.3.2 All Athletes participating in or preparing for IBU competitions are subject to Doping Controls** (urine samples, blood testing and other authorized techniques for detecting Prohibited Substances or Methods) in and out of competition.
- 1.3.3 All Member Federations must comply with these Rules** and shall include them either directly or by reference into their regulations. As far as possible, they shall report to the IBU Secretary General at the end of every year the results of all Doping Controls within their jurisdiction sorted by Athlete and identifying each date on which the Athlete was tested, the entity conducting the test, and whether the test was In-Competition or Out-of-Competition. When a Member Federation has received an Adverse Analytical Finding on one of its Athletes it must report all necessary details to the IBU and WADA within fourteen days of the result or waiver of the B sample. The Member Federation must also report to the IBU and to WADA any decision taken in this matter within fourteen days from this decision. The IBU reserves the right to apply its Anti-Doping and Disciplinary Rules directly on any such Athlete in case of non-compliance with any such decision.

2. OFFENCE OF DOPING AND ITS PUNISHMENT

- 2.1** Doping contravenes the fundamental principles of an Olympic winter sport federation, as well as of fair play and sports and medical ethics, and is forbidden.
- 2.2** Punishment for Doping and Trafficking with Prohibited Substances and the respective procedure is ruled by the IBU Disciplinary Rules.

3. PROOF OF DOPING

3.1 The IBU and its Member Federations shall have the burden of establishing that an anti-doping rule violation has occurred. The standard of proof, bearing in mind the seriousness of the allegation which is made, is greater than a mere balance of probability but less than proof beyond a reasonable doubt. Where these Rules place the burden of proof upon the Athlete or other Person alleged to have committed an anti-doping rule violation to rebut a presumption or establish specified facts or circumstances, the standard of proof shall be by a balance of probability.

3.1.1 Facts related to anti-doping rule violations may be established by any means, including admissions. The following rules of proof shall be applicable in doping cases:

- a. WADA-accredited laboratories are presumed to have conducted Sample analysis and custodial procedures in accordance with the International Standard for laboratory analysis. The Athlete may rebut this presumption by establishing that a departure from the International Standard occurred.
- b. If the Athlete rebuts the preceding presumption by showing that a departure from the International Standard occurred, then the IBU or its Member Federation shall have the burden to establish that such departure did not cause the Adverse Analytical Finding.
- c. Departures from the International Standard for Testing which did not cause an Adverse Analytical Finding or other anti-doping rule violation shall not invalidate such results. If the Athlete or other Person concerned establishes that departures from the International Standard occurred during Testing then the IBU or its Member Federation shall have the burden to establish that such departures did not cause the Adverse Analytical Finding or the factual basis for the anti-doping rule violation.

4. DOPING CONTROLS

4.1 Without any notice at any time and at any place, the IBU has the right to carry out Doping Controls, with and without the assistance of WADA or other organizations specialised in carrying out Doping Controls as agreed with them, of Athletes, including banned or suspended Athletes of IBU members. The members must support the

work of the IBU, especially in having the selected Athletes be brought to the announced place and providing all necessary information, including information on their training schedules giving dates and locations, as requested by the IBU Headquarters. This right of the IBU relates to all events practised within the IBU.

- 4.2** Doping Controls must be conducted at OWG, WCH, Y/JWCH, ECH and WC. The IBU EB will decide based on a recommendation by the IBU MC, in which other competitions Doping Controls will be carried out. The recommendation of the IBU MC is to be coordinated with the IBU TC.
- 4.3** In addition, the NFs are entitled to carry out further Doping Controls applying these Rules. If they find a doping case, they must report the facts and all respective decisions immediately to the Chairperson of the IBU MC and the IBU SG.
- 4.4** Doping Controls at WCH, Y/JWCH and other major events shall be carried out under the supervision of the IBU MD. The IBU MC shall appoint this MD for each event. This MD can be a member of the IBU MC or a qualified person designated by the IBU MC.
- 4.5** Out-of-Competition Doping Controls shall be conducted by agents of WADA or Persons or entities (hereafter "authorised agents") authorized by the IBU EB. Such Doping Controls can also be conducted by IBU MDs authorised by the IBU EB upon proposal of the IBU MC. Out-of-Competition Doping Controls are subject to these Rules.
- 4.6** All Samples provided by Athletes for the purpose of Doping Control shall become the property of the IBU.
- 4.7** All communications and correspondence intended for the IBU MC shall be sent to the IBU SG at the IBU Headquarters.
- 4.8** In connection with Doping Controls the official IBU representative, in the presence of a medical person, shall be entitled to enter and inspect rooms used by Athletes and their team officials and check their personal belongings with or without assistance of the respective national police authorities during IBU events starting with the first Official Training and ending with the end of the last competition.
- 4.9** A minimum of 30 male and 30 female athletes will comprise the IBU Registered Testing Pool (IBURTP). These athletes are selected

based on the prior year's World Cup Final Score. Athletes can be added to the IBURTP by virtue of their placing in the top twenty of any IBU World Cup ranking competition. Athletes can also be added when a change in performance or hematological profile is deemed significant when evaluated by the MC. Also Athletes who are serving periods of ineligibility as consequences of anti-doping rule violations are to be part of the IBURTP. Athletes belonging to the IBURTP are obligated to provide their whereabouts specifying for at least one hour per day where they can be located as per the IBU Whereabouts form. This information must be provided to their National Federation, IBU and WADA. They must update information, which shall be filed electronically, as necessary so that it is current at all times. This Whereabouts Information shall be shared by the IBU with WADA and other Anti-Doping Organizations having jurisdiction to test an Athlete on the strict condition that it be used only for Doping Control purposes. The NFs are obligated to coordinate the providing of the Whereabouts Information by their Athletes.

- 4.10** An Athlete who has been identified by the IBU for inclusion in the IBURTP will continue to be available for No Advance Notice Out-of-Competition Testing, unless and until the Athlete gives written notice to the IBU that he has retired or until he no longer satisfies the criteria for inclusion in the IBURTP and has been so informed by the IBU. An Athlete who has given notice of retirement to the IBU may not resume competing unless he notifies the IBU at least twelve months before he expects to return to competition and is available for unannounced Out-of-Competition Testing at any time during the period before actual return to competition.
- 4.11** In addition to Athletes included in the IBURTP, the Chairperson of the IBU MC may select Athletes for IBU Target Testing based on the following criteria:
- 4.11.1** Withdrawal or absence from expected Competition;
 - 4.11.2** Retirement;
 - 4.11.3** Behavior indicating doping;
 - 4.11.4** Changes in performance;
 - 4.11.5** Changes in Athlete Whereabouts Information that may indicate a potential increase in the risk of doping;

- 4.11.6** Changes in haematological profile;
 - 4.11.7** Details of past Doping Controls;
 - 4.11.8** Athlete reinstatement after a period of ineligibility; and
 - 4.11.9** Injury.
- 4.12** Doping Controls shall take place in substantial conformity with the current International Standard for Testing (including revisions that are continuously published by WADA). Completed tests must be promptly reported through the WADA Clearing House to avoid unnecessary duplication in Testing.
- 4.13** An Athlete in the IBURTP who is unavailable for Testing on three attempts during any period of 18 consecutive months shall be sanctioned. For each attempt, the Doping Control Officer must visit the locations during the times specified by the Athlete for that date and time and must stay for two hours at that location. Notification must be sent to the Athlete and his NF between each attempt which is to be counted as an unavailable test.
- 4.14** An Athlete who fails to timely submit his Whereabouts Information after receipt of two formal written warnings from the IBU or a NF to do so in the preceding 18 months shall hold responsibility according to the IBU Disciplinary Rules.

5. SPECIAL SITUATIONS FOR SUBSTANCE USE IN SPECIFIED MEDICAL CONDITIONS

- 5.1** All IBU Athletes with a documented medical condition requiring the Use of a Prohibited Substance or a Prohibited Method must first obtain a therapeutic use exemption (TUE) by the IBU Therapeutic Use Exemption Committee, which shall consist of three members of the IBU MC, all of them appointed by the chairperson of the IBU MC. The chairperson of the IBU Therapeutic Use Committee shall be authorised to deal with abbreviated therapeutic use exemption applications and must report on them to the IBU Therapeutic Use Committee. All other TUE applications shall be dealt with by the IBU Therapeutic Use Committee as a whole. The chairperson and the Committee have to consider a request for TUE by applying the current International Standard for Therapeutic Use Exemptions (including revisions that are continuously published by WADA). The

International Standard for Therapeutic Use Exemptions and all revisions shall come into effect for the IBU on 1 January after their publication by WADA. Each Member Federation shall be responsible for the content of the therapeutic use exemptions documents. The Member Federations are reminded to contact either the WADA website or the IBU SG for this information. Each Member Federation must ensure that the current International Standard for Therapeutic Use Exemptions is available to its members. All TUEs granted by the IBU shall be reported to the respective Athlete's NF and to WADA. TUEs granted by the NFs for Athletes competing on the national level must be promptly reported to the IBU and to WADA.

- 5.2** Requests of Athletes for a TUE by the IBU must be submitted, except in emergency situations, not later than 21 days before the Athlete's participation at an IBU competition. The decision on granting or denial of a TUE must be taken not later than 7 days before the Athlete's participation at the respective IBU competition. The Athlete has the right to appeal against this decision to the IBU EB. For the procedure, Article 13 of the IBU Disciplinary Rules shall apply accordingly. The decision of the IBU EB can be reviewed by WADA upon request from the Athlete. WADA shall also have the right to review on its own initiative the granting of TUEs. If WADA determines that such granting or denial did not comply with International Standards for TUEs, WADA may reverse the initial decision. The decision by WADA reversing the granting or denial of a TUE may be appealed to the CAS by the IBU EB or by the Athlete.

6. DOPING CONTROL LABORATORIES

- 6.1** Only Doping Control Laboratories accredited by WADA or otherwise approved by WADA and chosen by the IBU shall be entitled to analyze Samples taken at IBU Doping Controls. These laboratories shall be announced and updated by WADA on a continuous basis. These Laboratories will analyze Doping Control Samples in conformity with the current International Standard for Laboratory Analysis (with revisions published by WADA on a continuous basis) and report the results accordingly.
- 6.2** Doping Control Samples will be analyzed to detect Prohibited Substances and Prohibited Methods identified on the current WADA Prohibited List and other substances as may be directed by WADA or

IBU pursuant to the Monitoring Program described in Article 4.5 of the World Anti-Doping Code. No Sample may be used for any purpose other than the detection of Substances (or classes of Substances) or methods on the current WADA Prohibited List, or as otherwise identified by WADA pursuant to its Monitoring Program, without the Athlete's written consent.

- 6.3** Blood or other non-urine Samples may be used either to detect Prohibited Substances or Prohibited Methods or for screening procedure purposes only.

7. DOPING CONTROL PROCEDURES

7.1 SAMPLING, RESPONSIBILITY AND ORGANISATION

- 7.1.1** It is the responsibility of the MD and other authorised agents and persons, as mentioned above under Article 4 (Doping Control Officers – DCO) to ensure that the Doping Controls are conducted correctly.
- 7.1.2** At each event a Doping Control Committee (DCC) must be established. It shall consist of:
- the IBU MD as chairperson;
 - a person appointed by the Organizing Committee of the event and who is responsible for the Doping Control Station;
 - a representative of a national Doping Control Institution, if approved by the IBU Executive Board;
 - additional members such as assistants, interpreters, couriers, etc., to carry out the duties and functions of the DCC.
- 7.1.3** The main tasks of the DCOs shall be:
- inspection of the Doping Control Station where the Samples are to be taken;
 - ensuring that the necessary material for collecting the Samples is available;
 - technical guidance of the Doping Control Station personnel;
 - cooperation with the IBU TD with regard to the selection of the Athletes for examination;
 - verification of the identity of the Athletes to be tested;
 - collection of Samples, their coding and sealing, recording and packing as well as dispatching or surveillance of the whole process;
 - writing a report to be addressed to the chairperson of the IBU MC.

7.1.4 The Organising Committee will establish a secure Doping Control Station with adequate hygienic and ergonomic conditions that must consist of the following:

- a. a Control room (table, chairs, wash stand);
- b. an adjacent room with toilet and sink;
- c. a waiting room for Athletes and their accompanying officials;
- d. a bicycle ergometer if available.

7.1.5 The Doping Control Station must be situated near the arena and clearly marked on the outside. Refreshment drinks in sealed containers must be available in the waiting area.

7.1.6 Only the following persons shall be permitted to enter the Doping Control Station:

- a. The Members of the DCC and DCOs;
- b. the Athlete to be tested and his accompanying official;
- c. the IBU President and Executive Board Members and members of the IBU MC;
- d. the IBU TD;
- e. the IBU Race Director;
- f. international observers under the Independent Observer program according to article 20.3.7 of the World Anti-Doping Code.

7.1.7 The Organizing Committee will provide a heated Anti-Doping check point space in the vicinity of the entrance to the wax cabin area. This space can be a wax cabin, a trailer, tent etc.

7.2 URINE TESTING

7.2.1 Mode of Selection of Athletes for Urine Testing

- a. As a matter of principle, the best placed Athlete plus one additional Athlete whose name has been determined by a random draw have to undergo urine testing. The draw will be made immediately after the start of the first Athlete. The DCO will be responsible for holding the draw. Therefore, all Athletes who at the moment of the draw have not officially withdrawn from the competition, and whose names are drawn for testing, must undergo urine testing. In Senior and Junior World Championships, the Athletes placed 1 – 4 and one other Athlete drawn by lot will be tested after each competition. The same goes for one member of each team placed 1 – 4 and for one Athlete drawn by lot from another team. In Youth World Championships the best placed

Athlete and one additional Athlete chosen by random will be tested.

- b. In World Cups and Continental Championships the winner of each competition plus one other Athlete, in each competition, drawn by lot will undergo testing. The same goes for one member of the winning team and for one Athlete drawn by lot from another team. At each World Cup event, Doping Controls will take place.
- c. The IBU EB or the Medical Delegate can choose more Athletes for any type of urine testing without previous notice.
- d. WADA is given authorization to conduct its own tests as agreed upon with the IBU.
- e. Immediately after the competition or after the lots have been drawn, all Athletes selected for urine testing shall be handed a request to attend Doping Control by a Doping Control Escort (Chaperone) appointed by the DCC. From then on the Chaperone shall be physically beside the Athlete and keep the Athlete under observation at all times and accompany him to the waiting room at the Doping Control Station. When initial contact is made, the DCO must ensure that the Athlete is informed of his rights and responsibilities and of the location of the Doping Control Station. The Athlete shall report to the Doping Control Station with his accreditation card or national identification document immediately and no later than one hour after receipt of the request to attend Doping Control. It is the Athlete's responsibility to remain within the sight of the DCO and Chaperone at all times from the first moment of in-person notification by the DCO until the completion of the Sample collection procedure.

7.2.2 Collection of Urine Samples

- a. A person (a team coach, a doctor or a team-mate from the Athlete's team) and an interpreter may accompany the competitor to the Doping Control Station and may watch all procedures except urination. This accompanying person shall possess proper accreditation and shall be a member of the same team as the Athlete; in exceptional circumstances, the Athlete may choose a member of another team.
- b. Should the Athlete report to the Doping Control Station later than one hour after the time of notification, this fact must be noted in the record and the IBU TD must be informed of this directly. The Sampling procedure, nevertheless, shall be carried out like in all

other cases. Also an Athlete who has reported too late is entitled to be accompanied by an official from his team. However, the fact of late appearance may raise additional obligations of justification in the further procedure.

- c. A member of the DCC will prepare a Record of Doping Control, in duplicate, which must include the name of the Athlete, the country he represents, his start number, the time of notification and the time of arrival at the Doping Control Station.
- d. The Athlete and the accompanying person must remain in the waiting room of the Doping Control Station under supervision until the Athlete is called into the consulting area. The Athlete and any personal belongings he or the accompanying person bring with them (clothing, bags, etc.) may be searched for evidence of manipulation, upon entering and leaving the Doping Control Station.
- e. No photographs, video or tape recordings may be taken inside the Doping Control Station during the Doping Control procedure.
- f. Only one Athlete at a time shall be called into the Control room.
- g. The Athlete shall select a collection vessel, visually check that it is empty and clean, that all seals on the selected vessel are intact. If the Athlete is not satisfied with the selected vessel, he may select another. If the Athlete is not satisfied with any of the equipment available for the selection, this shall be recorded by the DCO. If the DCO does not agree with the Athlete's opinion that all the collection vessels available for the selection are unsatisfactory, the DCO shall instruct the Athlete to proceed with the Sample collection session. If the DCO agrees with the reasons put forward by the Athlete that all the collection vessels available for the selection are unsatisfactory, the DCO shall terminate the collection of the Athlete's urine Sample and this shall be recorded by the DCO.
- h. The Athlete shall proceed to the toilet and urinate a minimum of 75 ml into the collection vessel under the observation of a person appointed by the DCC who shall be of the same gender as the Athlete. Any clothing preventing the direct observation of the urination shall be removed. Then the Athlete shall return to the Control room with the collection vessel containing the urine and shall retain control of the collection vessel and any Sample provided until the Sample is sealed. The DCO or Chaperone shall

witness the Sample leaving the Athlete's body and record the witnessing in writing.

- i. The DCO shall use the relevant laboratory's specifications to verify, in full view of the Athlete, that the volume of the urine Sample satisfies the laboratory's requirements for analysis. If insufficient urine has been provided by the Athlete, the partial Sample must be placed in a box and locked. The Athlete will hold the box personally until he is able to urinate again. The DCO will keep the key until the Athlete is ready to urinate again. The Athlete will remain under observation until further urine has been provided and Sample taking procedures are complete.
- j. If the requested urine volume of 75 ml has been provided the Athlete will select another sealed plastic bag (Sample collection kit) which contains two bottles (for A and B Samples). The bottles may already have a code number engraved on them. Once a Sample collection kit has been selected, the DCO and the Athlete shall check that all code numbers match and that this code number is recorded accurately by the DCO. If the Athlete or DCO finds that the numbers are not the same, the DCO shall instruct the Athlete to choose another kit in accordance with the above procedure and record the matter. The Athlete himself will pour the urine into the bottles, that is to say first the relevant laboratory's prescribed minimum volume of urine into the B bottle, and then fill the A bottle as much as possible. The Athlete shall then fill the B bottle as much as possible with the remaining urine. A few drops of urine shall remain in the collection vessel. Next, the Athlete shall close the two bottles hermetically and check that no leak occurs. The Athlete shall seal the bottles as directed by the DCO. The DCO shall check, in full view of the Athlete, that the bottles have been properly sealed.
- k. Using the residual volume of urine in the collection vessel, the specific gravity and pH of the urine must be measured by the DCO as guided by the laboratory. These values will be recorded in the Record of Doping Control. If the specific gravity is lower than 1005, the entire Sampling procedure as described above must be repeated until the specific gravity of the demanded volume is 1005 or above. The DCO shall inform the Athlete that he is required to provide a further Sample. While waiting to provide an additional Sample, the Athlete shall remain under continuous

observation. The DCO shall record that the Samples collected belong to a single Athlete, and the order in which the Samples were provided. If it is determined by the relevant laboratory that none of the Athlete's Samples meet the laboratory's pH and specific gravity requirements for analysis and this is not related to natural causes, the Chairperson of the IBU Medical Committee shall schedule another Sample Collection Session for the Athlete as Target Testing as soon as possible. If the Target Testing Sample Collection Session also results in Samples that do not meet the laboratory's pH and/or specific gravity requirements for analysis, the IBU EB shall investigate a possible anti-doping rule violation. The non-performance of a second or further test cannot invalidate a positive doping result having been revealed by a Sample with gravity below 1005.

- l. The DCO shall ensure any residual urine that will not be sent for analysis is discarded in full view of the Athlete.
- m. The Athlete shall declare to the DCO any medication and dietary supplements that he may have taken in the preceding three days. The DCO shall record this statement on the Record of Doping Control.
- n. Any behaviour by the Athlete and/or persons accompanying him or anomalies with potential to compromise the Sample collection shall be recorded. If there are doubts as to the origin or authenticity of the Sample, the Athlete shall be asked to provide an additional Sample. In the case of an anomaly or if the Athlete refuses to provide an additional Sample, the DCO is responsible for ensuring that any matters in this case are assessed to determine if a possible failure to comply has occurred. The DCO is responsible for ensuring that all relevant information, including information from the immediate surroundings when applicable, is obtained as soon as possible or when practicable to ensure that all knowledge of the matter can be reported and be presented as possible evidence as well as that appropriate documentation is completed to report any possible failure to comply. Sample Collection Personnel are responsible for reporting to the DCO any matter with the potential to compromise a test, and the DCO is responsible for reporting such matters to the Chairperson of the IBU MC. The Athlete shall be notified of the possible consequences and that a possible failure to comply will be

investigated by the IBU EB and appropriate follow-up action will be taken. If possible, the Athlete's Sample Collection Session shall be completed. The President of the IBU and the chairperson of the IBU MC will ensure that the outcomes of its investigation are considered for results management action and, if applicable, for further planning and testing.

- o. In conducting the Sample Collection Session the following information shall be recorded as a minimum:
 - aa. Date, time and type of notification (No Advance Notice, Advance Notice, In-Competition or Out-of-Competition);
 - bb. Date and time of Sample provision;
 - cc. The name, date of birth, gender of the Athlete;
 - dd. The Athlete's home address and telephone number;
 - ee. The Athlete's sport and discipline;
 - ff. The Sample code number;
 - gg. The name and signature of the Chaperone who witnessed the urine Sample provision;
 - hh. The name and signature of the Blood Collection Official who collected the blood Sample, where applicable and as specified below;
 - ii. Required laboratory information on the Sample;
 - ij. Medications and supplements taken and recent blood transfusion details if applicable, within the time-frame specified by the lab as declared by the Athlete;
 - kk. Any irregularities in procedures;
 - ll. Athlete comments or concerns regarding the conduct of the session, if provided;
 - mm. The name and signature of the Athlete;
 - nn. The name and signature of the Athlete's representative, if required; and
 - oo. The name and signature of the DCO.
- p. The code number shall be entered into the Record of Doping Control. The Athlete and his accompanying official will check whether the numbers on the two bottles are identical with those in the Record of Doping Control.
- q. The persons listed above will sign the Record of Doping Control thus confirming that the Sampling has been conducted correctly. Any irregularities identified by the Athlete, accompanying official or the DCO must be recorded on the Record of Doping Control

before signing it. The original and one copy of the Record of Doping Control will be placed in two separate envelopes which must be closed and sealed with the IBU seal.

- r. The sealed envelope containing the original of the Record of Doping Control will be delivered to the chairperson of the IBU MC. The sealed envelope with a copy of the original will be delivered to the IBU SG. One other copy will be given to the Athlete. Two other copies (one for the A and one for the B Sample) will be sent to the Doping Control Laboratory that is to conduct the analysis. The copies sent to the Laboratory must not contain any information about the name or any identifying details of the Athlete or accompanying official.
- s. All the bottles with the A and B samples shall be placed in suitable transport containers, which are to be closed immediately after the Samples have been collected at the end of the competition, for transport.
- t. The bottles must be sent together with a customs declaration by the Organising Committee to the WADA accredited Doping Control Laboratory which has been selected by the IBU MC to carry out the analysis. The transport must take place in accordance with the directions stipulated by the Laboratory. The receipt of the samples must be confirmed in writing by the Laboratory Director or a person appointed by him to the IBU SG.
- u. Chain of Custody shall be checked by the chairperson of the IBU MC if receipt of either the Samples with accompanying documentation or Sample collection documentation is not confirmed at their intended destination or a Sample's integrity or identity may have been compromised during transport. In this instance, the Chairperson of the IBU MC shall consider whether the Sample should be voided.

7.2.3 Analysis of Urine Samples – Determination of Results

- a. During the analysis, only the Laboratory Director and his personnel, the Chairperson of the DCC of the IBU concerned or the Chairperson of the IBU MC, members of the IBU EB and the IBU TD and DCO, as applicable, shall have access to the Laboratory.
- b. The result of the analysis must be treated confidentially. It shall be communicated in an appropriate way only to the Chairperson of the IBU MC, the authorised agent and to the IBU SG.

- c. The results will be evaluated as designated to the tested Athletes by the Chairperson of the IBU MC and/or the DCO in cooperation with the IBU SG.
- d. Upon receipt of an A Sample Adverse Analytical Finding, the Chairperson of the IBU MC assisted by the IBU SG shall conduct a review to determine whether an applicable therapeutic use exemption has been granted, or whether there is any apparent departure from the current International Standards for Testing or Laboratory Analysis that undermines the validity of the Adverse Analytical Finding. If this review does not reveal an applicable therapeutic use exemption or departure from the Standards mentioned above that undermines the validity of the Adverse Analytical Finding, the IBU SG shall promptly notify the Athlete in writing and the representative of the team concerned, if this team is still at the competition site. If the team has already left when the Adverse Analytical Finding of the analysis becomes available, the IBU SG will notify the Athlete and the NF involved.
- e. This notification shall include the Adverse Analytical Finding, the anti-doping rule violated, any follow-up investigation as may be required by the current WADA Prohibited List and its results, including the assertion, whether an anti-doping rule was violated; the Athlete's right to promptly request the analysis of the B Sample or, failing such a request, that the B Sample analysis may be deemed waived; the right of the Athlete and/or his representative to attend the B Sample opening and analysis if such analysis is requested; and the Athlete's right to request copies of the A and B Sample laboratory documentation package which includes information as required by the current International Standard for Laboratory Analysis. The Athlete's NF must demand an explanation from the Athlete, which explanation, if any is given, must be relayed to the IBU SG.
- f. The test analysis, if so requested, shall be conducted at the same Laboratory under the supervision of a member of the IBU MC within three weeks of the notification under Article 7.2.3 d. above. The NF of the Athlete in question is entitled to send a maximum of three representatives to the Laboratory to attend the analysis of the B Sample. The IBU is entitled to proceed with the B Sample analysis even if so waived by the Athlete.

- g. The member of the IBU MC will forward the result of the second examination to the IBU SG. If the B Sample proves negative, the entire test will be considered negative and the Athlete and his NF so informed. In case of a second positive result the IBU SG will initiate the necessary procedures, and inform the Athlete, his NF and WADA. The NF concerned will pay all expenses that have been incurred due to examination of the B Sample.
- h. For apparent anti-doping rule violations that do not involve Adverse Analytical Findings, the IBU SG will conduct any necessary follow-up investigation and will then promptly notify the Athlete and his NF of the anti-doping rule which appears to have been violated, the basis of the violation and the further procedure under the IBU Disciplinary Rules.

8. BLOOD AND GENE TESTING

8.1 PURPOSE

Blood tests shall be organized to determine haematological parameters. Blood tests may also be used to detect doping substances. Gene tests shall be organized to detect whether gene or cell doping, i.e. the non-therapeutic Use of genes, genetic elements and/or cells that have the capacity to enhance athletic performance, has taken place.

8.2 MODE OF SELECTION OF ATHLETES FOR BLOOD TESTING

- 8.2.1 a. Before each competition in a World Cup and a World Championship and before other competitions according to Executive Board ruling following recommendation by the Medical Committee, at least six Athletes, chosen by drawing lots, must undergo a blood test. All Athletes who are to be found on the start list at the time of the draw shall be included in the draw. The lots shall be drawn according to the contingencies of the venue between three (3) and two (2) hours before the start of zeroing. The draw shall take place under the direction of the Medical Delegate.
- b. The Chairperson of the OC, the Medical Delegate and the Race Director will agree upon a system of collecting the drawn Athletes for each venue. The system must be announced for each venue at the first Team Captains Meeting. Immediately after the draw, the

start numbers of the Athletes selected for blood testing will be announced on a sign posted at the entrance to the Doping Control Station and on the Athletes Compound Information Board.

- c. The procedure for implementing the agreed system must follow the directions of the Medical Delegate and RD.
- d. Depending on the chosen system, Athletes should either stay at their lodgings until an hour before the start of zeroing or must assemble at the Athletes Compound at the latest 45 minutes before zeroing. The Athletes will identify themselves to the Chaperones by presenting their accreditation card. Athletes selected for blood testing will sign the Doping Control Form and remain with the Chaperone until they arrive at the Doping Control Station. The Athlete shall be considered having been informed as soon as the notification has been given to his team.
- e. With the exception of proven cases of force majeure, absence from the arranged blood test shall count as refusal of the Doping Control according to Article 7.8 of the IBU Disciplinary Rules with the consequences being suspension according to Article 7.6.1 and further testing (a urine test).
- f. As long as Athletes have not been officially withdrawn from the start list by the start of the draw, they shall undergo a blood test. Also, all those Athletes who officially withdrew after the draw shall be subject to blood testing, should their lot be drawn. Upon Doping Control notification, the Athletes in question must sign a declaration of notification and make their way promptly to the Doping Control Station with their Chaperone. The Chaperones must remain with their Athlete from this time on, the entire time until the start of their Athlete's blood test.
- g. WADA is given authorization for a given number of tests as agreed upon with the IBU following the procedure above.

8.2.1.1 The Chairman of the Medical Committee of the IBU shall have the authority to select additional Athletes for blood and gene testing.

8.2.2 All blood Samples shall only be taken by qualified personnel (Blood Collection Officials), appointed by the IBU MC with the supervision of a MD or other DCO.

8.3 COLLECTION OF BLOOD SAMPLES

8.3.1 Article 7.2.2 above shall apply accordingly, as far as not otherwise specified below.

- 8.3.2** At the time indicated the selected Athletes must come to blood testing. Should problems occur and the Athlete is not capable of undergoing blood testing at the scheduled time, the time of Sampling can be delayed until five minutes before the start of the first competitor in exceptional cases.
- 8.3.3** The Athlete must declare to the DCO and/or Blood Collection Official any blood transfusions he received in the preceding months, giving the date, the reasons for the blood transfusion and the name of the physician or hospital that administered the transfusion. The official receiving the declaration must record these statements in the Record of Doping Control.
- 8.3.4** If the Athlete wants to refuse to permit blood Sampling, the possible consequences of his refusal must be explained to him by the DCO. If the Athlete continues refusing, this fact will be noted in the Record of Doping Control and will be signed by the Official. The Athlete and the person accompanying him are requested to sign as well. The respective Official shall inform the Chairperson of the IBU MC of the blood Sampling refusal.
- 8.3.5** The DCO shall ensure the Athlete is offered comfortable conditions including being in a relaxed position for at least 10 minutes prior to providing a Sample. The DCO shall instruct the Athlete to select the Sample collection kit/s required for collecting the Sample and to check that the selected equipment has not been tampered with and the seals are intact. Article 7.2.2. g. above shall apply accordingly.
- 8.3.6** The Blood Collection Official shall clean the skin with a sterile disinfectant wipe or swab in a location unlikely to adversely affect the Athlete or his performance and, if required, apply a tourniquet. The Blood Collection Official shall take the blood Sample of a maximum of 2 x 3 ml of venous blood from a superficial forearm vein.
- 8.3.7** Should it not be possible to take the blood Sample within three attempts, the Blood Collection Official shall inform the DCO. The DCO shall terminate the collection of the blood Sample and record this and the reasons for terminating the collection. The blood testing will be considered passed if the failure depended only on the incapacity of the operator and not on the behaviour of the Athlete.

- 8.3.8** The Blood Collection Official shall apply a dressing to the puncture site(s) and shall dispose of used blood sampling equipment not required for completing the Sample Collection Session.
- 8.3.9** Should more Athletes be waiting for blood Sampling, the sequence will be conducted in the expected Sampling order. An Athlete arriving late at the Doping Control Station will be shifted to the end of the list.
- 8.3.10** If the blood is drawn for analysis in a laboratory then a sealed container kit certified by WADA will be used. The Athlete shall seal his Sample into the Sample collection kit as directed by the DCO. In full view of the Athlete, the DCO shall check that the sealing is satisfactory.
- 8.3.11** If the blood is drawn for analysis in a laboratory then the sealed Sample shall be kept at a cool, but not freezing, temperature prior to dispatch for analysis at the WADA accredited laboratory or as otherwise approved by WADA.

8.4 IMMEDIATE ANALYSIS OF BLOOD SAMPLES

If the blood is drawn for analysis of haematological parameters then a single syringe will be used without use of a sealed blood collection kit. The blood Samples collected shall be analyzed with regard to the value of reticulocytes and haemoglobin using an appropriate measuring instrument, approved by the IBU MC, in the presence of the Athlete and, if he agrees, of one accompanying person, and within a maximum of two days after the collection.

8.4.1 Determination of Results with Regard to Haemoglobin

- a. When the results of the analysis show a value of haemoglobin which exceeds 17.5 g/dl in males and 16 g/dl in females, the same Sample will be re-tested two times more, and the average of the three tests will be the final result.
- b. Immediately after this, a report of the results will be printed and given to the Athlete. Should a result exceed the limits as described above, the Athlete, the official accompanying him and the DCO will sign a form declaring the temporary inability of the Athlete to compete. On the same form, the Athlete will have the opportunity to give an explanation. A copy of the form will be given to the Athlete.

- c. The remaining blood will be kept anonymously and subsequently destroyed. The numerical results of haematological parameter analyses will become the property of the IBU and become part of the IBU haematological data base. This data may be used for anti-doping purposes in any appropriate way.

8.4.2 Consequences of Exceeded Haemoglobin Values

- a. If the final result exceeds 17.5 g/dl (males) or 16 g/dl (females), the respective Athlete will be subject to a suspension for health reasons as a matter of precaution. The suspension shall take immediate effect from the respective competition until blood re-testing shows haemoglobin values below 17.5 g/dl for male and 16 g/dl for female Athletes.
- b. Only blood re-tests performed using appropriate measuring instruments approved by the IBU MC, and under IBU supervision, will be accepted. A blood re-test cannot be performed earlier than five days after the initial blood test showing exceeded haemoglobin values. A blood re-test must take place at the latest before the next event, if the period between the initial blood test showing exceeded haemoglobin values and the next event exceeds five days.
- c. The blood re-test necessary to become eligible for competition again can be performed by appropriate haematological departments designated by the IBU MC, upon proposal of the respective Athlete or his Federation in addition to at the international events in which blood testing is conducted and supported by the IBU. The costs for this testing will be charged to the Athlete's Federation.
- d. If a blood re-test does not exceed the limits, the Athlete will be able to resume the competitions.
- e. Any modification of the procedure for blood testing and re-testing must be authorised by the IBU MC to be considered valid.
- f. Athletes whose normal values exceed the limits described above under Article 8.4.2.a. must provide a certificate issued by a Haematological Department for the competition season in which they want to start and submit this certificate to the chairperson of the IBU MC 14 days at the latest before the first competition of the season for approval. The IBU MC shall have the right to re-test these Athletes at each competition where blood testing is intended.

- g. The blood re-testing performed or supervised by the IBU MC will be conducted immediately before the normal blood testing.
- h. The Athlete will immediately undergo a urine test according to Article 7.2 above.

8.4.3 Determination of Results with Regard to Reticulocytes and Consequences of Exceeded Values

If the blood test shows a higher value of reticulocytes than 2.0%, the Athlete must undergo a urine test according to Article 7.2 above combined with an additional blood test and shall be subject to the same sanctions.

8.4.4 Questions to Resolve

- a. If at any stage in the proceedings a question or issue to be clarified arises concerning testing or interpretation of results, the person in the laboratory responsible for conducting testing may consult the DCO or the Chairperson of the IBU MC.
- b. If at any stage in the proceedings a question or issue to be clarified arises in relation to the Sample, the laboratory may conduct any further tests necessary to clarify the facts or issue so raised, and such tests may be relied upon by the IBU when deciding whether a Sample has tested positive for a Prohibited Substance or Method.

8.4.5 Statistics

At the end of a competition season, the chairperson of the IBU MC will compile statistics on the names of Athletes and number of times they were invited for blood testing.

9. OUT OF COMPETITION TESTING

9.1 Out-of-Competition Testing are Doping Controls in addition to those conducted at and during IBU competitions. The costs of Out-of-Competition Testing are covered by the IBU and WADA respectively.

9.2 The IBU may commission specialised organizations (e.g. International Doping Tests & Management) to perform Out-of-Competition Testing. Out-of-Competition Testing shall end on the day before a competition and start at the earliest one day after a competition. Out-of-Competition Tests by WADA shall be carried out on the basis of the respective agreement signed with WADA. After the necessary coordination arrangements have been made between

the organization and the IBU regarding the selected Member Federation, Sample Collection Personnel from the organization, who are equipped with a letter of appointment of the IBU, must be granted the desired access to the training area for the purpose of performing a Doping Control on the selected Athlete(s). The same goes for WADA Sample Collection Personnel who must be equipped with a letter of appointment from WADA. The letters of appointment carrying the IBU or WADA letterhead must be shown to the selected Athlete(s); a copy must be left with him/them. All Sample Collection Personnel must also show the selected Athlete(s) proof of identity.

9.3 MODE OF SELECTION OF ATHLETES FOR OUT OF COMPETITION TESTING

- a. Each Member Federation must provide the IBU SG with a complete list with addresses of all its Athletes belonging to the IBURTP for the coming season, and where and when the training camps will be held. Each Athlete listed on it must be informed by his NF that he is one of those people eligible for Out-of-Competition Testing by the IBU, WADA or an organization commissioned by the IBU. Analogous obligations have to be observed with regard to and by Athletes selected for Target Testing.
- b. The Chairperson of the IBU MC shall select the nation and the names of the Athletes to be tested.
- c. The Member Federations can be informed of the arrival of the DCOs and of the names of the Athletes to be tested.
- d. The Member Federations are requested to help to arrange a specific time, location and place for Sample collection and must arrange a meeting with the Athletes selected for testing.

9.4 INDEPENDENT SAMPLING OFFICER (ISO)

- a. Sample Collection Personnel who are sent by the IBU shall be called Independent Sampling Officers. They shall either be members of IBU Committees with appropriate training or employees of organizations specialised in Doping Controls. They will be appointed by the IBU EB, as far as possible based on the advice of the IBU MC.
- b. The IBU MC shall maintain a register of persons selected by the IBU to act as ISO's.
- c. Before an ISO or WADA Sampling Officer may legally conduct Out-

- of-Competition Testing, he must have received a letter from the IBU specifying where and when he is to conduct this testing.
- d. ISOs must be available to travel on short notice. The IBU Headquarters will assume charge of the travel arrangements including procuring visas. ISOs will be selected taking geographical aspects into account as well.

9.5 COLLECTION OF SAMPLES

- a. The Sample Collection Personnel will require proof of the identity of the Athlete. This will involve photographic proof of identity (passport, ID card, etc.). The Sample Collection Personnel may also require a photograph of the Athlete to be taken.
- b. The same procedures as listed for collection, storage and transport of the respective Samples (urine or blood) during In-Competition Testing must be followed as far as applicable.
- c. The Sampling Officer shall continually make every effort to act as discreetly as possible during Sample Collection for analysis for Prohibited Substances or Methods and with respect for the Athletes' privacy. Every effort will be made by the controller to collect the Sample as speedily and efficiently as possible and with the minimum of interruption to the Athlete's training plans and his social and professional life. However, if there is a disruption then no Athlete may take action to gain compensation for any inconvenience caused.
- d. If an Athlete fails to report to the agreed Doping Control Station, the Sampling Officer has to inform the IBU MC of this. In cases where such an arrangement has been made, it is the Athlete's responsibility to check prior to the arranged meeting that there is no possible confusion about the arranged date, time and precise location where the meeting will take place. The Sampling Officer will wait up to two hours past the time agreed, but thereafter the athlete will be declared absent from testing.
- e. If the Athlete refuses to provide a Sample, the Sampling Officer must explain to the Athlete that by refusing to provide a Sample, he shall be deemed to have refused to submit to Doping Control and will be subject to the same sanctions as if having been doped according to the IBU Disciplinary Rules. If the Athlete still refuses to provide a Sample, the Sampling Officer shall note this in the Record of Doping Control, sign his name on the form and ask the

- Athlete to sign the form. Furthermore the Sampling Officer should also note any other irregularities in the Doping Control process.
- f. As for the transport of Samples to the Laboratory, if at all possible, the outer container should not be opened during transit. The respective Sampling Officer will provide identification labels in the event that they are required for customs formalities. However, the opening of the outer container will not, of itself, invalidate the Doping Control.

10. ENTRY INTO FORCE

The IBU EB approved this version of the IBU Anti-Doping Rules provisionally in June 2006, pending adoption by the IBU Congress in September 2006. This last amended version adopted by the Congress 2006 entered into force on 3 September 2006.